

LAVINA

S7 SERIES

Operation Manual
25/30/31 Propane Grinders



- L25GS7**
- L25GKS7**
- L30GS7**
- L30GKS7**
- L31GS7**

TABLE OF CONTENTS

1.	INTRODUCTION	4
1.1.	MANUFACTURER	4
1.2.	GENERAL DESCRIPTION	4
1.3.	ENVIROMENTAL CONDITIONS	4
1.4.	WARRANTY AND RETURNS	4
1.4.1.	WARRANTY POLICY FOR LAVINA® MACHINES	5
1.4.2.	RETURN POLICY FOR LAVINA® MACHINES	6
2.	SAFETY INSTRUCTIONS.....	7
2.1.	RECCOMENDED USE.....	7
2.2.	PROHIBITED USE.....	7
2.3.	PREPARATION FOR WORK	7
2.4.	SAFE USE.....	8
2.5.	PROPANE SAFETY.....	8
2.6.	FIRE SAFETY	9
2.7.	EMISSIONS.....	9
2.8.	HAZARD COMMUNICATION	9
2.9.	LOCAL AGENCIES AND REGULATIONS	10
2.10.	RESIDUAL RISKS	11
2.11.	BEFORE YOU BEGIN.....	11
2.12.	OPERATING THE MACHINE	12
2.13.	AFTER WORK IS COMPLETED	12
2.14.	THE WORK AREA.....	12
2.15.	PERSONAL PROTECTIVE EQUIPMENT (PPE)	12
2.16.	TESTING	13
2.17.	OPERATOR	13
2.18.	PROPANE CYLINDERS	14
2.19.	REFUELLING CYLINDERS.....	14
2.20.	STORAGE CYLINDERS	15
2.21.	TRANSPORTING CYLINDERS	15
3.	MACHINE DESIGN	16
3.1.	MAIN COMPONENTS.....	16
3.2.	TECHNICAL DATA.....	18
3.3.	TOOL HOLDER RPM RANGE	19
3.4.	VIBRATIONS.....	21
3.5.	SONOROUS EMISSIONS.....	21
3.6.	LABEL DATA.....	21

3.7.	CUSTOMER SERVICE	21
4.	TRANSPORTATION AND STORAGE.....	22
4.1.	TRANSPORTATION	22
4.2.	LIFTING.....	22
4.3.	SUPPORT WHEEL	23
4.4.	STORAGE	23
5.	SUPERABRASIVE LPG CONTROLLER	23
5.1.	SYSTEM COMPONENTS	24
5.2.	OVERVIEW OF THE FEATURES.....	24
5.2.1.	CLOSED LOOP FUEL MANAGEMENT SYSTEM	24
5.2.2.	FAULTY O2 SENSOR DETECTION.....	24
5.2.3.	EMMISSIONS WARNINGS AND SHUTDOWN.....	24
5.2.4.	DUAL HOUR METERS	24
5.2.5.	BATTERY VOLTMETER	25
5.2.6.	ENGINE TACHOMETER	25
5.2.7.	JOB TIMER	25
5.2.8.	SERVICE ALERTS.....	25
5.2.9.	MAIN MENU NAVIGATION AND USE	26
5.3.	ELECTRONICS MODULE OF DIGITAL FUEL CONTROL SYSTEM	28
6.	OPERATING THE MACHINE	29
6.1.	PROTECTIVE COVER	30
6.2.	ADJUSTING THE HANDLE.....	30
6.3.	ADJUSTING THE WEIGHTS.....	31
6.4.	WATER FEED.....	32
6.5.	CONTROL BOARD.....	32
6.6.	MOUNTING TOOLS.....	33
6.7.	STARTING THE MACHINE	34
6.8.	WHILE OPERATING THE MACHINE.....	34
6.9.	STOPPING THE MACHINE	34
7.	TOOLS AND ACCESSORIES	35
7.1.	RECOMMENDED TOOLS	37
8.	MAINTANANCE AND INSPECTATION	39
8.1.	MECHANICAL PARTS	39
8.2.	CLEANING	39
8.3.	CHECK DAILY	40
8.3.1.	TOOL HOLDERS	40
8.4.	ENGINE MAINTENACE.....	41
8.4.1.	KAWASAKI FX 600	41
8.4.2.	KOHLER PCV740	45

- 8.4.3. VANGUARD 993CC..... 49
- 8.5. QUICK ENGINE TROUBLESHOOTING GUIDE 52
- 8.6. OVERALL MAINTENANCE..... 52
- 9. TROUBLESHOOTING 53
 - 9.1. ENGINE 53
 - 9.2. SEPARATING THE CARRIAGE FROM THE GRINDING HEAD 54
 - 9.3. ENGINE DRIVE 56
 - 9.3.1. REPLACING THE BELT 56
 - 9.3.2. CHANGING THE CENTRAL PULLEY OR THE CLUTCH..... 58
 - 9.4. REPLACING THE MAIN TIMING BELT 60
 - 9.4.1. ACCESSING THE PLANETARY DRIVE 66
 - 9.4.2. SINCHRONIZING THE PLANETARY DRIVE 68
 - 9.5. PLANETARY DRIVE WITH CHAIN TENSIONER..... 71
 - 9.5.1. MAINTENANCE 72
 - 9.6. TOOLHOLDERS 73
 - 9.6.1. REPLACING V RINGS AND FELT RINGS 73
 - 9.6.2. REPLACING THE BUFFERS AND THE ELASTIC ELEMENT 74
 - 9.7. REPLACING THE PULLEY UNITS 76
- 10. BATTERY 77
 - 10.1. REPLACING/CHARGING THE BATTERY..... 77
- 11. EMMISION CONTROL WARRANTY STATEMENT 78
 - 11.1. CALIFORNIA EMISSION CONTROL WARRANTY STATEMENT YOUR WARRANTY RIGHTS AND OBLIGATIONS..... 78
 - 11.2. MANUFACTURER'S WARRANTY COVERAGE 78
 - 11.3. OWNER'S WARRANTY RESPONSIBILITIES 78
 - 11.4. GENERAL EMISSIONS WARRANTY COVERAGE 79
 - 11.5. WARRANTED PARTS..... 80

1. INTRODUCTION

This owner's manual is intended for the operator of our machines, the servicing technician as well as for anyone involved with operating or servicing the machine. We recommend that you read the instructions very carefully and follow them strictly. The manual includes information about assembling, using, handling, adjusting and maintaining your machine.

1.1. MANUFACTURER

Superabrasive was founded in 1987, as a manufacturer of high quality diamond tools for stone and concrete industry. Today, Superabrasive is one of the world's leading companies in the production of diamond tools and floor grinding machinery. At Superabrasive, we strive to deliver the very best solutions to our customers, and enable them to work more efficiently.

1.2. GENERAL DESCRIPTION

The Lavina® machines are designed for grinding, polishing and buffing concrete, marble, granite, limestone and terrazzo surfaces with diamond tools. Additionally, the machine could be used for grinding wood floor surfaces.

This Lavina® machine is a three disc machine, which can be used wet or dry. For best results, use only tools manufactured or recommended by Superabrasive and its distributors.



This machine is manufactured and fitted for the above-mentioned applications only! Every other use may possess risks to the persons involved.

1.3. ENVIRONMENTAL CONDITIONS



The temperature range of operating the machine is between 41°F-86°F or 5°C-30°C. Never use the machine during rain or snow when working outdoors. When working indoors, always operate the machine in well-ventilated areas.

1.4. WARRANTY AND RETURNS

1.4.1. WARRANTY POLICY FOR LAVINA® MACHINES

A warranty registration form must be submitted to Superabrasive within 30 days of purchase in order for the foregoing warranty to apply. You can fill out the form on our web page <https://superabrasive.com/warranty-registration/>.

Superabrasive warrants, from the time of delivery and receipt by the original customer, new and unused products sold by Superabrasive or Superabrasive-appointed distributors or dealers. Goods shall be free from defects in materials and workmanship. Superabrasive or a Superabrasive-appointed repair facility shall either replace or repair any defects in the Goods resulting from faulty design, materials, or workmanship. Products repaired or replaced during the warranty period shall be covered by the foregoing warranty for the remainder of the original warranty period, or ninety (90) days from date of the repair or shipment of the replacement, whichever is longer. Spare parts for repair will be either new or equivalent to new.

Warranty period shall be 2 years from the time of delivery and receipt by the original customer, or 600 operating hours on the machine - whichever occurs first. Superabrasive will cover the shipping charges for the transportation of the machine to Superabrasive (or an approved repair facility) and back to the customer (within the contiguous 48 United States) in the event that the damage occurs and is reported within 200 operating hours. Shipping charges, if covered by Superabrasive, must be agreed upon in advance and approved by Superabrasive. Thereafter, the customer will have to cover the shipping charges to Superabrasive and back. Superabrasive will not warranty Goods after a period of 2 years from the time of delivery and receipt by the original customer, or 600 operating hours on the machine - whichever occurs first.

Superabrasive shall not be liable for any defects that are caused by circumstances that occur after the Goods have been delivered and whilst the Goods are in the possession of the purchaser. Furthermore, the warranty does not include normal wear and tear or deterioration. Wear parts are not warranted. Superabrasive is not liable for defects arising out of use of non-OEM parts.

The Warranty is void if the purchaser has not followed the maintenance plan stipulated by the machine's manual and warranty card. The warranty is void if the purchaser repairs said Goods himself, or if repairs are conducted by a repair facility that is not approved by Superabrasive. Superabrasive's liability does not cover defects which are caused by faulty maintenance, incorrect operation, faulty repair by the purchaser, or by alterations conducted without Superabrasive's prior written consent. The same applies to any alterations of the Goods or services performed by another party other than Superabrasive, a Superabrasive-appointed distributor, or a Superabrasive-approved repair facility. The warranty is not applicable on a defect that arises due to tools or parts that are not original to Superabrasive. Replaced defective parts shall be placed at Superabrasive's disposal and shall become property of Superabrasive. If such defective parts are replaced within the warranty period, the shipping charges will be covered by Superabrasive. In warranty complaint cases, when no defects are found for which Superabrasive is liable, Superabrasive

shall be entitled to compensation for the labor, material cost, and shipping charges, incurred by Superabrasive as a result of the complaint.

The warranty herein is non-transferable, and only applies to the original owner or purchaser of the machine.

1.4.2. RETURN POLICY FOR LAVINA® MACHINES

The Lavina® machines may be returned, subject to the following terms: In no case, a machine is to be returned to Superabrasive Inc. for credit or repair without prior authorization. Please contact Superabrasive Inc. or your local distributor for an authorization and issuance of a return authorization number. This number along with the serial number of the machine must be included on all packages and correspondence. Machines returned without prior authorization will remain property of the sender and Superabrasive Inc. will not be responsible for them. No machines will be credited after 90 days from the date of invoice.

All returns must be shipped freight prepaid. Returned machines may be exchanged for other equipment or parts of equal dollar value. If machines are not exchanged, they are subject to a fifteen percent (15%) restocking fee.

2. SAFETY INSTRUCTIONS

2.1. RECOMMENDED USE

The Lavina® machine is designed and manufactured to grind and polish concrete, terrazzo and natural stone floors. It can be used for renovations as well as for polishing.

The machine is designed for dry or wet use. When using it dry, use a vacuum of appropriate size. For more information, please refer to the chapter on handling the vacuum connection.

2.2. PROHIBITED USE

The machine MUST NOT be used:

- For applications different from the ones stated in the “General description” chapter.
- In environments which:
 - Possess risks of explosion;
 - Possess high concentration of powders or oil substances in the air;
 - Possess risks of fire;
 - Feature inclement conditions;
 - Possess electromagnetic radiation;
 - In nursing homes, hospitals, day-care centers, etc.;
 - In areas where loose tiles or other objects are preventing proper use of the machine;
 - In rooms without proper ventilation;

2.3. PREPARATION FOR WORK

Make sure that:

- The work area is closed so that no person unfamiliar with operating the machine can enter the area.
- There are no missing parts of the machine.
- The machine is in upright working position.
- The protection devices are working properly.

Protection devices

- The machine is equipped with several protection devices including following:
 - A protection skirt and hood for protecting the tool plates.

- CO shut-off module;

These devices protect the operator and/or other persons from potential injuries. Do not remove them. On contrary, before using the machine, please ensure that all protection devices are mounted and function properly.

Arrest functions:

- Functions of arresting the machine are following:
 - Switch to stop the engine;
 - Button to disengage the clutch and stop the grinding movement;
 - EMG stop button;
 - Close the propane tank;

2.4. SAFE USE

The Lavina machine is designed to reduce all risk correlated with its use. However, it is not possible to fully eliminate the risks of an accident with the machine. Unskilled or uninstructed operator may cause correlated residual risks. Such risks are:

- Position risks due to operator's incorrect working position;
- Entanglement risks due to wearing inappropriate working clothes;
- Training risk due to lack of operational training;

2.5. PROPANE SAFETY

- Propane is flammable gas whose vapors are heavier than air. As it the case with gasoline, propane can explode if the proper cautions are not heeded. Propane is odorized with an agent having a distinct odor that is recognizable at very low concentrations. This helps in identifying leaks, even when they are small.
- Awareness and basic safety precautions are required when working with propane. As long as these precautions are followed, risk is negligible. Ignorance, however, could pose needless risk.
- The two greatest hazards with propane powered floor care machines are:
 - **Carbon monoxide poisoning:** This is the most frequently reported incident associated with propane powered floor care machines and is caused by excessive exhaust emissions. The symptoms are headache, dizziness and nausea. A major cause involves engines with poor preventive maintenance practices, usually those with dirty air filters and machines operated in confined areas without adequate ventilation. Another cause may be substandard,

inexpensive machines with no emissions control technology and improperly set carburetion.

- **Overfilled fuel cylinders:** Nearly all fire related incidents reported result from bringing a cylinder into a building without first checking for overfill. This action is dangerous, unwise, and unnecessary.

2.6. FIRE SAFETY

- Be aware of the potential dangers of fire or explosion when using propane, and take normal fire- safety precautions.
 - **Fire:** There is a possibility of fire from LPG vapor leaking or venting from fuel cylinders or carburetion equipment.
 - **Explosion:** LPG vapor concentrated or confined to a small, restricted space may explode or ignite.
 - **Propane:** may experience a **BLEVE**, a boiling liquid expanding vapor explosion.

2.7. EMISSIONS

- All propane powered floor care machines emissions. Most are harmless, but some are dangerous and can be fatal. Carbon monoxide (CO) poses the greatest risk, since CO can be lethal within as little as 30 minutes exposure at 3,000 parts per million (ppm) concentration.
- Carbon monoxide is an invisible, odorless, colorless gas created when fossil fuels (such as gasoline, wood, coal, propane, oil and methane) burn incompletely.

2.8. HAZARD COMMUNICATION

- A Material Safety Data Sheet for propane shall be posted in all buildings where propane will be used.

Because propane is odorized, it is easily detected at levels of just a few parts per million, which is much less than the exposure limit of 1000 parts per million.

If you smell propane while operating a propane floor care machine, stop the engine and do the following:

- Pull the throttle to the stop position (if present) or turn the key switch to the off position.
- Shut off the service valve on the propane cylinder.

- Move the machine to well ventilated area.
- Remove the cylinder from the machine and take it outside the building.
- If cylinder is leaking, contact a DOT approved repair shop to determine the cause of the leak and have the shop, not you, repair it.

If a fire occurs while the machine is being operated, do the following:

- Stop the engine by pulling the throttle to the stop position or turn the key switch to the off position.
- Shut off the service valve on the propane cylinder if possible. Be careful not to be burned.
- Move the machine outside if possible. If not, move it to a well-ventilated area away from flammable materials.
- Do not attempt to extinguish the flame from a gas leak. If you do, the gas will build up in the area and could re-ignite. Starve the fire by shutting off the supply of gas.
- Have the machine and cylinder inspected before using them again.

2.9. LOCAL AGENCIES AND REGULATIONS

▪ NFPA

Operating a propane powered floor care machine requires compliance with certain safety regulations. The National Fire Protection Agency (NFPA) Standard for Storage and Handling of LP Gas is the appropriate authority for safe propane use. A copy of this publication is available through the NFPA in Quincy, MA (1-800-334-3555).

Among its regulations, NFPA #58 requires that all personnel employed in the handling of propane gas be trained in its proper handling and operating procedures. It also requires them to carry a written certification from their employer or training supervisor to attest to such training. Although this is directed mainly to those who fill and transport liquid propane gas, Onyx Environmental Solutions recommends that operators of propane powered floor care machines in public places be trained and certified as well.

With regard to operation of propane powered floor care equipment, even though NFPA 58 8 4.5 says “these machines shall be permitted to be used in buildings frequented by the public, including the times when such buildings are occupied by the public,” Onyx Environmental Solutions suggests usage when occupancy of a given work area is minimal.

▪ CARB/EPA

The California Air Resource Board (CARB) and Environmental Protection Agency (EPA) also set limits for propane powered engines used outdoors, but CARB/EPA approval does not signify that the engine is safe to use indoors.

- **CGA**
The Canadian Gas Association (CGA) has set a limit of 1500 ppm CO in exhaust flow.
- **OSHA**
For propane powered machines used indoors, the Occupational Health and Safety Administration (OSHA) has established a limit of 50 ppm CO for 8 hour time weighted average (TWA) in ambient air and is considering a limit of 800 ppm CO in exhaust flow.
- **DOT**
The Department of Transportation (DOT) has established regulations regarding the safety of fuel cylinders including the ones used on propane powered floor care machines.
- **Local Agencies**
Local law enforcement agencies such as the local Fire Marshall also rely on independent testing labs such as UL and CGA before giving their approval of the use of some equipment. These labs thoroughly test equipment and submit their stamp of approval only after rigorous testing. While not being required by all law enforcement agencies, the stamp of approval by these agencies further assures the operator that he or she is working with and around safe equipment.
NOTE: In order to reduce all consequences of the above mentioned risks, we advise that machine operators will follow the instructions in the manual at all times.

2.10. RESIDUAL RISKS

- During the normal operating and maintenance cycles, the operator is exposed to a few residual risks, which cannot be eliminated due to the nature of the operations.

2.11. BEFORE YOU BEGIN

- Clear the working area of any debris or objects.
- A first-time operator must always read the manual and pay attention to all safety instructions.
- All propane connections and cables must be inspected for potential damages.
- Perform general daily inspections of the machine and inspect the machine before each use.
- Always inspect the safety devices.
- The tool protector must be working.
- Mount the security disk when working with “Quickchange” pads.

- The machine must be clean.
- Never operate the machine outdoors in rainy or snowy weather.
- Confirm that there are no missing parts especially after transportation, repair or maintenance.
- Before filling the water tank with water, make sure the machine is not running and the main switch is turned off.
- Before turning on the machine, make sure that the base is placed on the floor. The machine MUST NOT be in a titled position when starting.

2.12. OPERATING THE MACHINE

- When operating the machine, make sure that there is no one, but you around the machine.
- Never leave the machine unattended while working.
- The water hose must move freely and must be damage-free.
- Make sure the working surface is not too uneven. If it is, it may damage the machine.

2.13. AFTER WORK IS COMPLETED

- Clean the machine and its surroundings properly.
- Empty and clean the water tank.
- Store the machine in a safe place.
- Place the propane tank outside in a designated storage area.
-

2.14. THE WORK AREA

- Prevent people or vehicles from entering the work area.
- Clear all hoses and cables from the work area.
- Always check the floor for debris.

2.15. PERSONAL PROTECTIVE EQUIPMENT (PPE)

- Always wear a safety shoes when working with the machine.
- Always wear ear protectors when working with the machine.
- All personnel in the immediate work area must wear safety glasses with side shields.
- Always wear safety gloves when changing the tools.
- Always wear clothes suitable for the work environment.

- Always wear carbon monoxide indicator badges as an extra precaution.
- The plastic indicator contains a colored indicator button that darkens in the presence of Carbon Monoxide. The relative darkness of the indicator button indicates the level of CO in the ambient atmosphere. Most indicator badges have a useful life of 30 days, depending on the concentration of contaminants, humidity, and temperature.

2.16. TESTING

- There are great number of instruments offered on the market to test for toxic gases. Only those designed to read carbon monoxide resulting from combustion engines are considered acceptable for testing exhaust emissions from propane powered floor grinding machines.
- Some instruments are used to read “ambient air” and may be damaged if used to take readings in the muffler or tail pipe. Selecting the proper instrument is an important part of meeting the testing requirements.
- Generally speaking, units capable of reading in ppm (parts per million), at ranges from 0 to 1000 are adequate for checking ambient air (air in the breathing zone of the operator). Instruments capable of testing carbon monoxide in the exhaust should be able to read from 0 to at least 2000 ppm and should be certified by the manufacturer for that purpose.
- All instruments used for testing must be calibrated at intervals recommended by the manufacturer. The monitor, model number and date of calibration will be recorded with all the result.

2.17. OPERATOR

- The operator must know the machine’s work environment.
- Only one operator can work with the machine at a time.
- The operator must be properly trained and well instructed prior operating the machine.
- The operator must understand all the instructions in this manual.
- The operator must understand and be able to interpret all drawings and designs in manual.
- The operator must know all sanitation and safety regulations pertaining to the operation of the machine.
- The operator must know what to do in case of emergency.
- The operator is expected to operate his equipment safely and responsibly. He is responsible for the proper handling and storage of propane cylinders, identifying potential hazards associated with his job and avoiding these hazards at all times.

2.18. PROPANE CYLINDERS

- The Propane cylinders are constructed of either aluminum or steel. We recommend aluminum because it is lighter and guards against rusting. The cylinder used on propane powered floor machines is classified as a 4E240 cylinder. Its rated capacity is 20 lbs. and this designation refers to the model of the cylinder. Actual propane capacity achieved during filling can be less than, equal to, or slightly more than 20 lbs. Use only UL, CTC/DOT listed cylinders.
- The propane cylinder used on the floor machine is a motor fuel cylinder as listed by the Department of Transportation. Unlike the common 20 lb propane outdoor grill cylinders (which are not legal for use on propane floor machines), the motor fuel cylinder has a number of safety systems designed into it to ensure your safety at all times.
- There are two types of 20 lb. motor fuel cylinders. Liquid draw and vapor draw.
- The liquid draw cylinder is used on larger vehicles like forklifts. These machines have special vaporizing carburetors to allow the propane to change from a liquid to a gas before being burned in the combustion chamber.
- The vapor draw cylinder is used on small machines like the propane powered floor care machines. The vacuum generated by the engine draws up the Propane gas vapor through the fuel system. The propane powered floor care machine does not have an evaporating system and will freeze up if liquid propane is introduced to it. It is necessary that special attention be paid to ensure that neither the liquid nor the vapor draw cylinders be overfilled.

2.19. REFUELLING CYLINDERS

- The proper filling of propane cylinders is a subject so important that it warrants special attention. Propane cylinders should only be filled by qualified propane dealers.
- Most important, propane cylinders should be filled no more than 80% of their rated capacity. The other 20%, which is about 4" (10 cm) from the top of the cylinder, is called the vapor space or headspace. This vapor can be compressed without causing the pressure relief valve to open and vent gas to the area around the cylinder. If there is no headspace to allow for fuel expansion, the pressure relief valve will open, releasing propane gas into the atmosphere. This is a very dangerous and volatile situation as there is always the possibility that enough of the vented gas could find its way down to the floor and come in contact with a pilot light from a furnace, hot water heater, or other source of ignition. Propane changes into a gas, is -44°F (-42° C). Exposing unprotected skin to propane gas or liquid could result in frostbite injury.

- All new cylinders should be vented and purged of air per manufacturer's instructions before use. Never bleed propane cylinders indoors.

2.20. STORAGE CYLINDERS

- When not in use, propane cylinders always should be stored outside in an upright position in a secure, tamperproof, steel mesh storage cabinet. This cabinet may be located next to the building but with at least five feet (1.5 m) of space between the cabinet and the nearest building opening (door or window), also away from heat and direct sunlight.
- Do not install the cabinet near a stairway or street elevator as vented propane gas will seek a lower level since it is heavier than air and could find its way into the basement of the building. Do not store cylinders full or empty inside a building or inside a vehicle. Although it is unlikely that propane will vent from a stored cylinder, if it should, the vapor could come in contact with an ignition source such as a spark from a power tool or other appliance and create a flash fire.
- Do not smoke or use a device with an open flame when handling or transporting propane cylinders.

2.21. TRANSPORTING CYLINDERS

- When transporting cylinders to a propane dealer or to a job, make sure the cylinders are securely fastened and standing in an upright position with the service valve closed.
- A cylinder rattling around in the back of a vehicle and banging into other objects constitutes a hazard. Avoid dropping or banging cylinders against sharp objects.
- The propane cylinders are sturdily constructed but a series of hard jolts could cause damage.
- Please note that any cylinder that has been filled is always considered full, no matter how little propane gas remains in it. This is because even when all liquid has evaporated into vapor there is still some propane gas vapor left in the cylinder. Because this remaining fuel is flammable, an empty cylinder should be treated with the same careful procedures as one that is filled to the 80% level with liquid propane. The

only time that a cylinder is considered empty is when it is new, before it has been filled with propane.

- When transporting a propane powered floor machine, the propane cylinder may be strapped onto the machine as long as the machine itself is firmly secured in the vehicle.
- Of course, spare cylinders should always be secured in an upright position.

3. MACHINE DESIGN

3.1. MAIN COMPONENTS

- The machine contains two main components – the carriage and the grinding head.
- The machine is equipped with three LED lights, which enable the operator to work in dark areas. Existing lighting system does not replace adequate overhead lightning.
- The propane tank is placed on the backside of the frame. The machine is designed to work only with 20 lbs. vertical propane tank.
- The control panel is positioned on the machine's handle bar.
- The handle bar is equipped with two positioning mechanisms, which are designed to provide the operator with the most convenient operating position for him.
- The machine is equipped with three way water tap that provides the operator to choose between the water tank and external hose as a water source. Also a secondary water tap which allows the operator to adjust the water flow level.
- The vacuum hose port is situated on the back of the machine. It's either 2.5" or 3" depending on the machine size (25" or 30").
- The two weights are designed to take four different positions for optimal grinding pressure.
- The machine's power source is the engine mounted on the top of the grinding head.
- There are three "QUICKCHANGE" tool holders on the bottom of the grinding head. They provide fast and secure mount and dismount of our "QUICKCHANGE" tools.

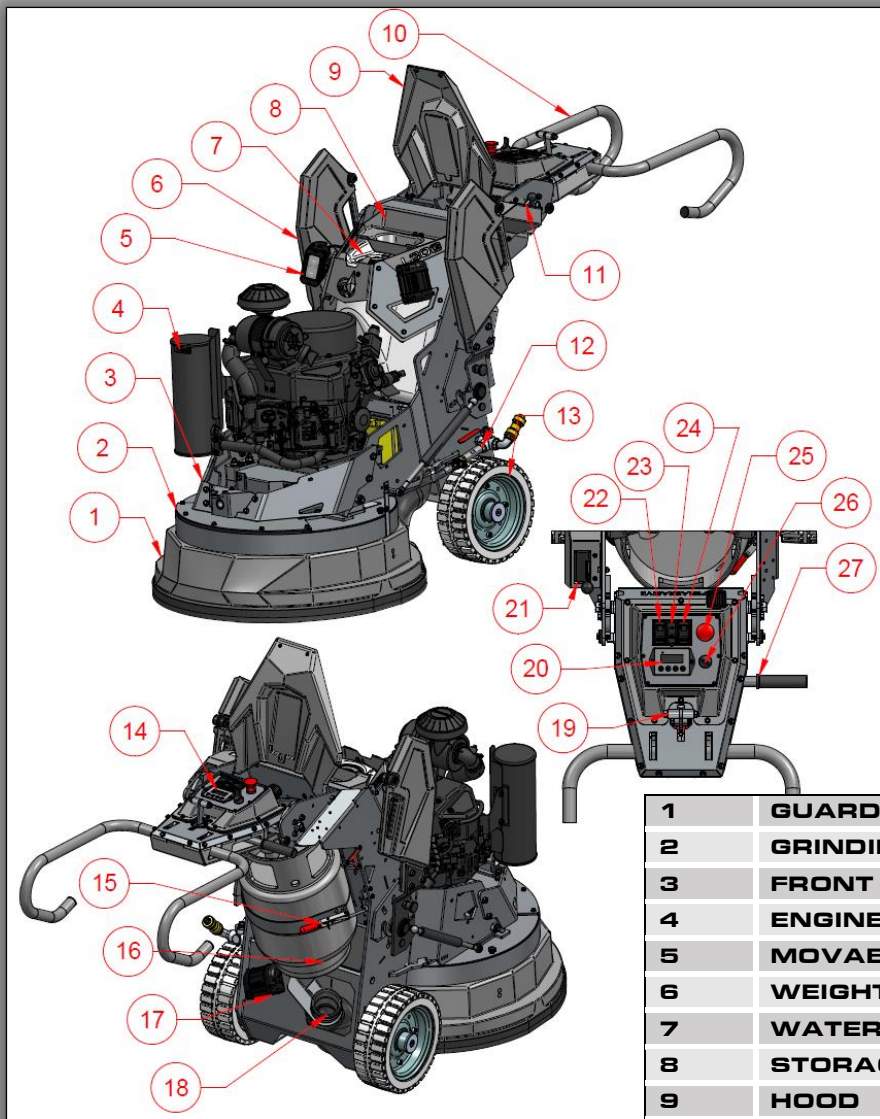

1	GUARD
2	GRINDING HEAD
3	FRONT BUMPER
4	ENGINE
5	MOVABLE LIGHT
6	WEIGHT
7	WATER TANK
8	STORAGE COMPARTMENT
9	HOOD
10	HANDLE
11	THROTTLE LEVER
12	WATER MANAGEMENT
13	WHEEL
14	CONTROL BOARD
15	PROPANE TANK STRAP
16	PROPANE TANK
17	STATIC LIGHT
18	VACUUM HOSE PORT
19	HANDLE FINE ADJUSTMENT
20	CONTROLLER
21	THROTTLE CONTROLLER
22	CLUTCH SWITCH
23	USB CHARGER
24	LIGHTS ON/OFF
25	EMG STOP BUTTON
26	ON/OFF SWITCH
27	HANDLE ROUGH ADJUSTMENT

3.2. TECHNICAL DATA

LAVINA®	L25GS7	L25GKS7	L30GS7	L30GKS7	L31GS7
Engine power, kW/hp	14.2/19	17.9/24	14.2/19	17.9/24	26/35
Engine speed, rpm	2000-3600	2000-3600	2000-3600	2000-3600	2000-3600
Working width, mm/in	673/26.5"	673/26.5"	783/30.8"	783/30.8"	783/30.8"
Tool holder direction of rotation	Counterclockwise	Counterclockwise	Counterclockwise	Counterclockwise	Counterclockwise
Tool holder diameter, mm/in	3x225/9"	3x225/9"	3x335/13.2"	3x335/13.2"	3x335/13.2"
Tool holder speed of rotation, rpm	607-1100	607-1100	425-765	425-765	425-765
Tools cutting speed, m/s	7.3-13.1	7.3-13.1	7.3-13.2	7.3-13.2	7.3-13.2
Weight, kg/lbs	401	409	412/908	420/926	460/1014
Grinding pressure kg/lbs	157-241/346-531	165-249/363-549	168-252/370-556	176-260/388-573	178-313/392-690
Weights in position 1 (forward), kg/lbs	241/531	249/549	252/556	260/573	313/690
Weights in position 2 (vertical 1), kg/lbs	201/443	209/461	212/467	220/485	270/595
Weights in position 3 (vertical 2), kg/lbs	171/377	179/394	182/401	190/419	248/546
Weights in position 4 (rearward), kg/lbs	157/346	165/363	168/370	176/388	178/392
Max grinding pressure with accessory weight	N/A	N/A	N/A	N/A	360/794
Water tank, L/gal	20/5.2	20/5.2	20/5.2	20/5.2	20/5.2
Water feed	Water tank/External source	Water tank/External source	Water tank/External source	Water tank/External source	Water tank/External source
Propane tank capacity, kg/lbs	9/20	9/20	9/20	9/20	9/20
Application	Wet and dry	Wet and dry	Wet and dry	Wet and dry	Wet and dry
Vacuum hose port	CAMLOCK E250	CAMLOCK E250	CAMLOCK E300	CAMLOCK E300	CAMLOCK E300
Recommended dust extractor	V25E/GE or bigger	V25E/GE or bigger	V32E/GE	V32E/GE	V32E/GE
Machine LxWxH, mm/in	2140x722x1158 84"x28.5"x46"	2140x722x1158 84"x28.5"x46"	2184x818x1158 86"x32"x46"	2184x818x1158 86"x32"x46"	2195x818x1158 86.5"x32"x46"
Packing create LxWxH, mm/in			1470x840x1315/ 57.9x33x51.8		

3.3. TOOL HOLDER RPM RANGE

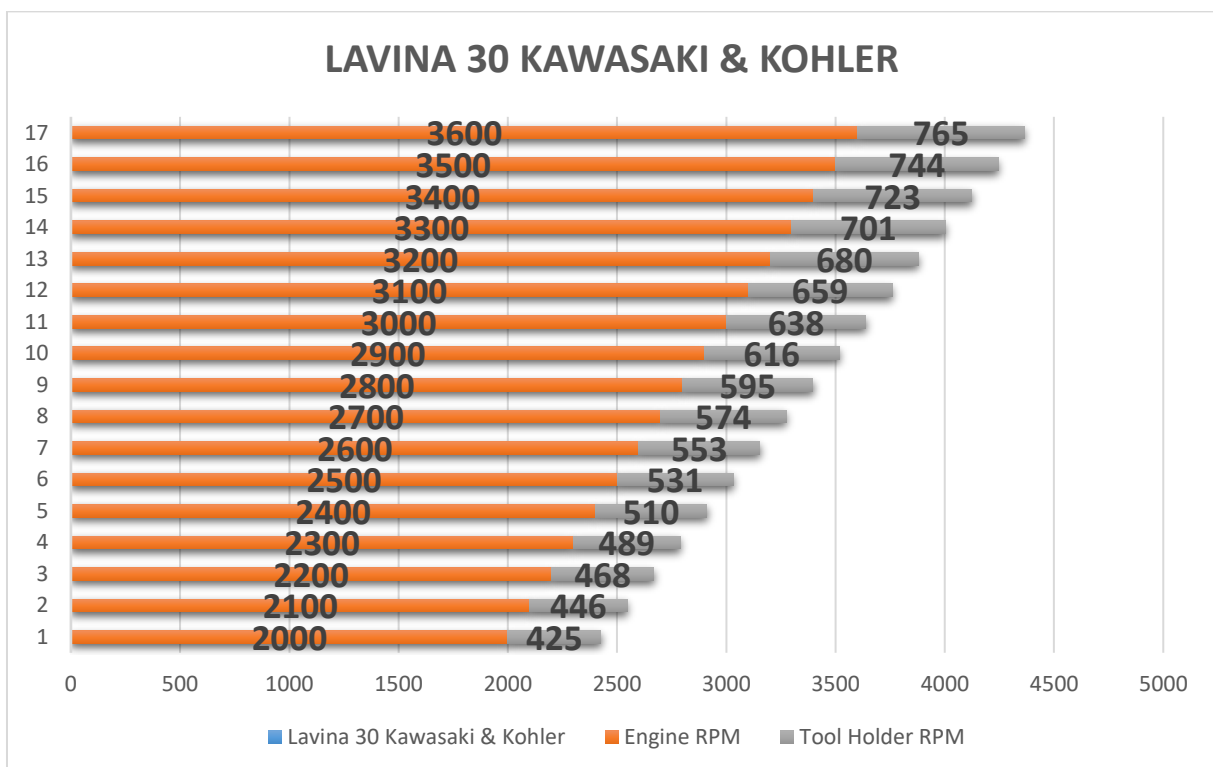
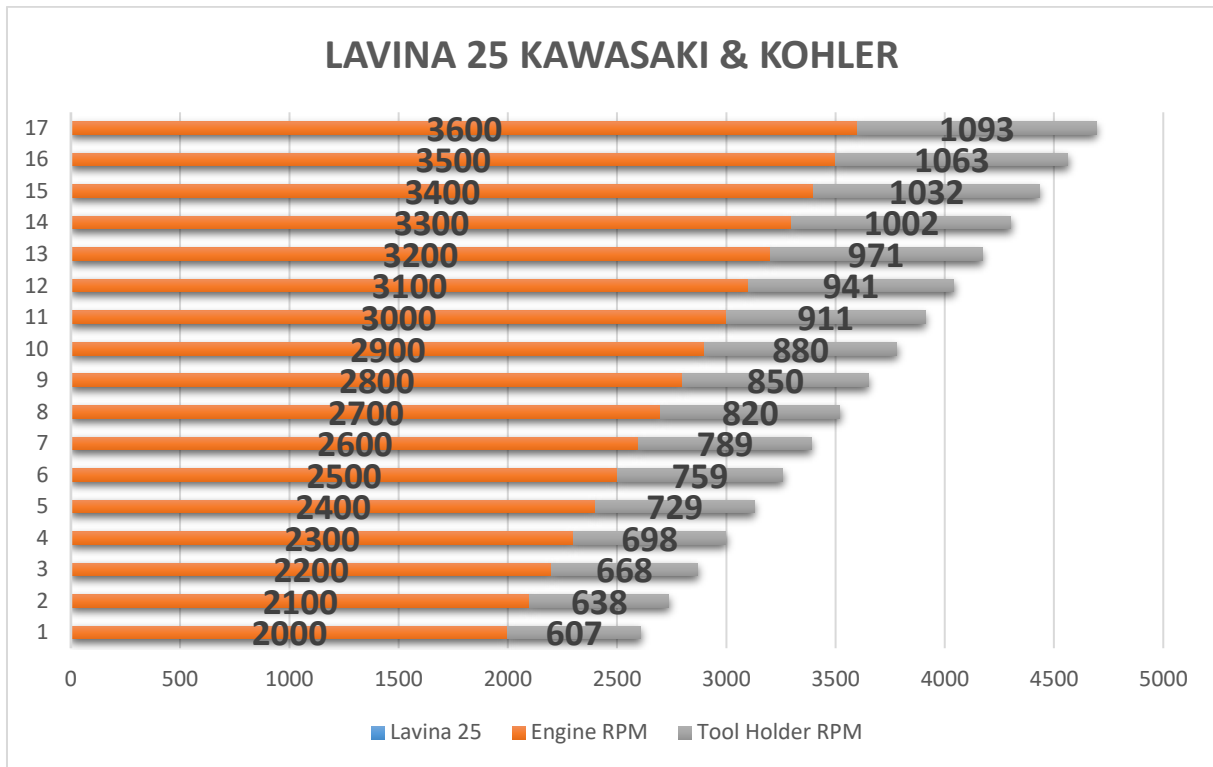

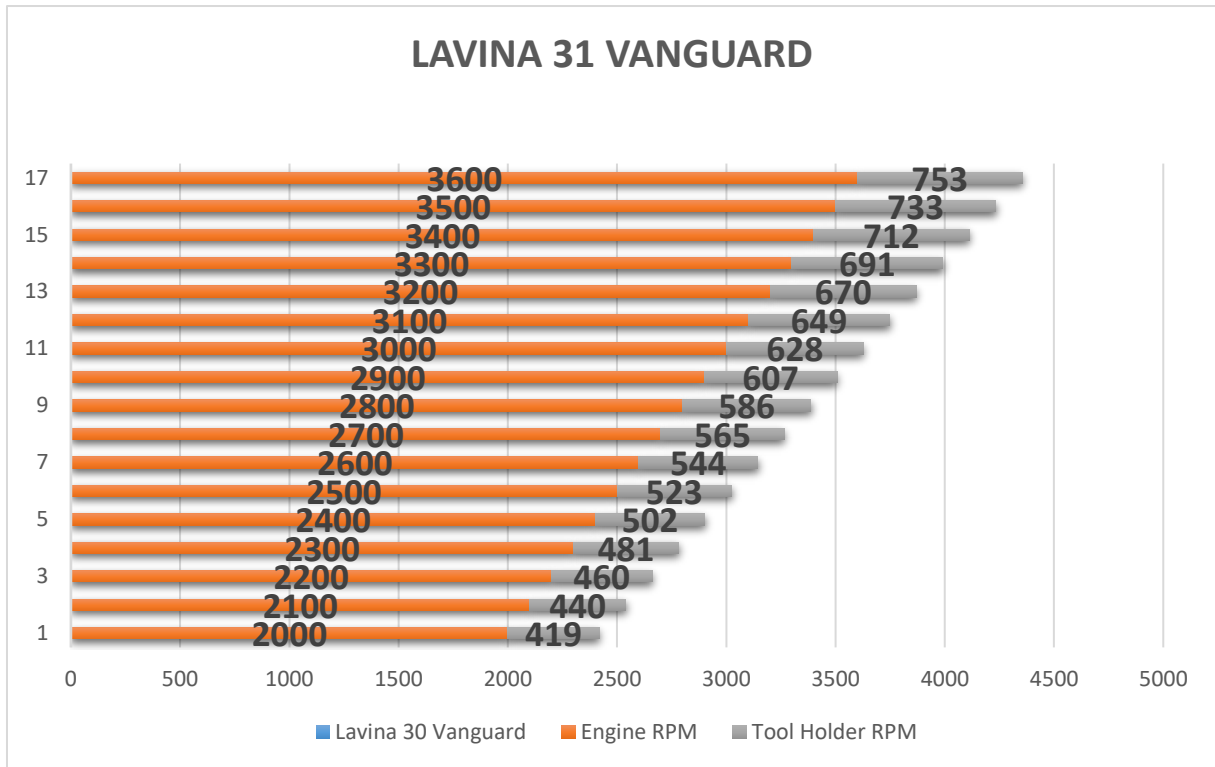

3.4. VIBRATIONS

The vibrations of the machine are within the limits of directives and harmonized standards from European Union when the machine is operated with recommended tools and in normal conditions.

3.5. SONOROUS EMISSIONS

The sonorous emissions are within the limits of directives and harmonized standards from the European Union when the machine is operated with the recommended tools and in normal conditions. However, as previously stated, the operator must wear ear protectors.

3.6. LABEL DATA

The data on the label provides correct information about the machine:

- Engine power;
- Weight;
- Year of production;
- Serial number;

3.7. CUSTOMER SERVICE

For customer assistance and technical support call your local distributor or call Superabrasive at 1-800-987-8403 for US or visit our website www.superabrasive.com.

4. TRANSPORTATION AND STORAGE

4.1. TRANSPORTATION

The Lavina machine has four fixing points which are used for strapping the machine during transportation.

NOTE: Always make sure that the machine is securely anchored to its surroundings and that the grinding head is lowered on to the surface. Tighten the securing straps, or other equipment used for anchoring during transport over non-moving parts, e.g. the machine's chassis.

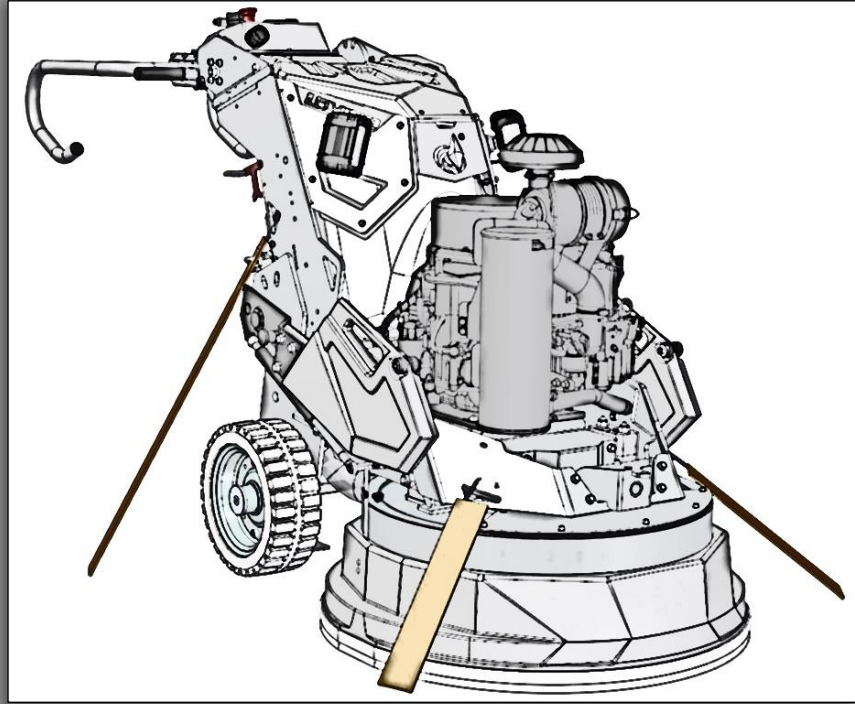

Never transport the machine unprotected. It can be damaged if transported unprotected and exposed to rain or snow. The weights must be in pos. 1 as shown on the image.

4.2. LIFTING

To lift the machine, make sure that the weights are in the backwards position in order to keep the machine imbalanced.

In order to avoid damage, make sure that the protective cover of the grinding head is locked in the transport position (6.1).

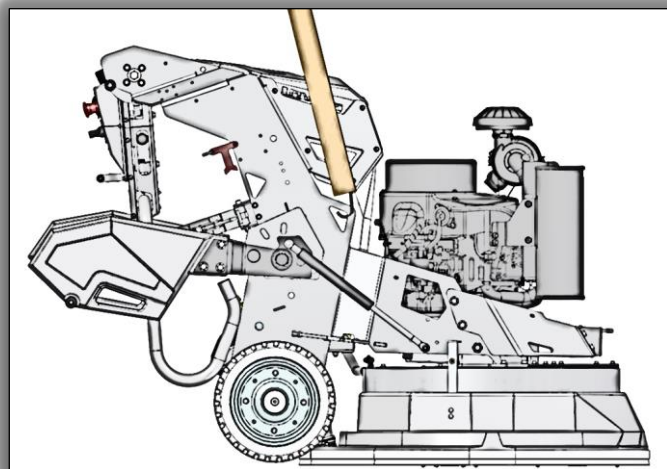

4.3. SUPPORT WHEEL

The support wheel (L30GE02.10.00-1) is designed to make moving and transporting the machine easier. It is offered as an accessory and must be ordered separately from the machine. The wheel can stay mounted while machine is in operation (grinding and polishing).

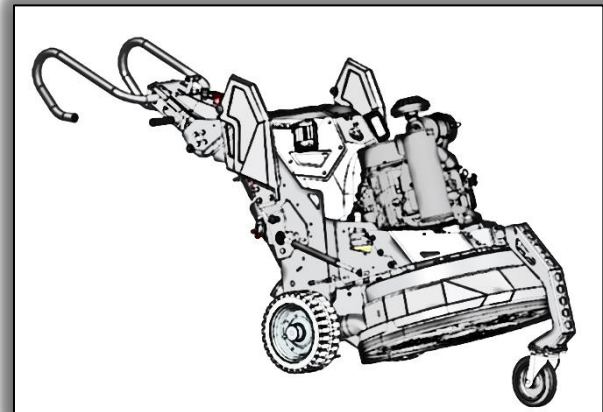
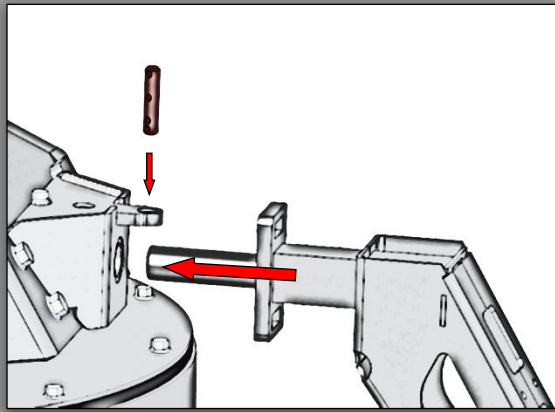

4.4. STORAGE



Always store the machine in dry place.

When the machine is in storage and the temperatures are falling down below 32F or (0°C) you must empty the water from the system to avoid damage.

Leave opened internal and external valves in order to drain the water from the system.

5. SUPERABRASIVE LPG CONTROLLER

The Superabrasive (SA) LPG controller is a high-performance, digital fuel control system featuring closed loop feedback, fuel lock-off capability, emissions safety warnings with shutdown and LCD screen for user interface. The system is highly responsive to changes in engine load, providing the optimum air to fuel ratio regardless of operating conditions.

5.1. SYSTEM COMPONENTS

The following parts are included with the system:

- Electronic module;
- Integrated wire harness;
- Fuel control valve;
- Fuel control housing;
- O2 sensor;
- LPG regulator with lock off;

Individual items are available as replacement parts if necessary.

5.2. OVERVIEW OF THE FEATURES

5.2.1. CLOSED LOOP FUEL MANAGEMENT SYSTEM

The SA LPG controller uses closed-loop feedback from the O2 sensor to control the amount of fuel introduced to the engine via the fuel control valve. The technology continuously monitors engine emissions and is capable of making fuel corrections to compensate for varying engine loads and conditions.

5.2.2. FAULTY O2 SENSOR DETECTION

If a faulty O2 sensor is detected, the SA LPG controller will alert the user within 3-5 minutes from a cold start. A message will be displayed on the LCD screen to let the user know that the O2 sensor needs to be replaced.

5.2.3. EMISSIONS WARNINGS AND SHUTDOWN

If the SA LPG controller detects carbon monoxide emissions, it will shut the engine via kill switch. For LED color coding, read the CO shut-off module specification.

5.2.4. DUAL HOUR METERS

The SA LPG controller has two hour meters, one for the engine and the other for the equipment. The engine hours are resettable, which should only be done if the

engine is replaced. The equipment hours is non-resettable and shows the total hours on the equipment, similar to the odometer of a vehicle.

5.2.5. BATTERY VOLTMETER

The feature allows for real-time display of the battery's voltage, which also helps for troubleshooting any battery or charging system issues that may arise.

5.2.6. ENGINE TACHOMETER

Displays the current engine speed in rpm. This should be used to assess proper idle, WOT and engine speed for the appropriate tooling.

5.2.7. JOB TIMER

The job timer feature works when the engine is running with equipment and will not continue to run if the engine is stopped. The job timer allows for easy timing of jobs or work areas to help determine speed. Resetting the job timer is password protected.

5.2.8. SERVICE ALERTS

The SA LPG controller provides equipment specific service alerts for the following items:

- Air filter;
- Oil change + oil filter change;
- Spark plugs;
- Seal replacements;
- Chain inspections;
- Belt inspections;
- Tooling inspections;

Each item has individual alerts at different hour intervals, and the SA LPG controller will start alerting the user when the hour interval is over. To reset a particular service alert, simply press the "Enter" button. The intervals will start to blink then press and hold the "+" and the "Enter" buttons for a couple of seconds. The interval should be reset.

5.2.9. MAIN MENU NAVIGATION AND USE

This section outlines how to navigate the menu and interact with certain features.

5.2.9.1 MAIN MENU

The main menu contains the following screens, which can be viewed by simply using the “+” and “-” buttons to scroll:

- **Operational information** – This is default screen. It displays the battery’s voltage and tachometer (current engine speed in rpm).
- **Alarm status** – Shows if there is an alarm from the MT05 communication of the Kohler engine or from the CO shut-off module.
- **Engine hours** – Displays the total number of hours (idle mode and clutch engaged).
- **Equipment hours** – Displays the number of hours on your equipment when the machine is with engaged clutch.
- **Job timer** – The job timer acts as a stopwatch, but only starts when the machine works with clutch engaged. This allows you to accurately time how long your engine runs for a particular job.
- **Service menu** – when you enter this menu, you have access to the service intervals of the machine. Alarm message indicates when an interval is over. Then you should take particular action and reset the interval.
- **Diagnostics menu** – When you enter this menu, you have access to the CO shut-off module status and the clutch state (engaged or not).
- **Machine number** – The machine serial number is entered here from the manufacturer.
- **About** – This screen displays the manufacturer’s name. Hardware and software versions too.

Please note: Upon startup, the first screen shown is always “Operational information” (battery voltage and tachometer).

5.2.9.2 LED ALERTS & RESETTING SERVICE INTERVALS

The SA LPG controller will alert you when service is due. To reset the service interval see text above – service alerts.

The controller will indicate high levels of Carbon Monoxide. For LED color codes, see CO shut-off module specifications.

For machines with a Kohler engine the controller will also indicate fault codes.
For details, see table below.

FAULT CODE	CONNECTION OR FAILURE DESCRIPTION	FAULT CODE	CONNECTION OR FAILURE DESCRIPTION
0031	Oxygen Sensor Heater Circuit High Voltage	0172	Minimum Adaptation Limit Exceeded
0032	Oxygen Sensor Heater Circuit Low Voltage	0174	Lean Fuel Condition at High Load (Open Loop) or Insufficient Fuel Supply.
0107	Manifold Absolute Pressure Sensor Circuit Low Voltage or Open	0201	Injector 1 Circuit Malfunction
0108	Manifold Absolute Pressure Sensor Circuit High Voltage	0202	Injector 2 Circuit Malfunction
0112	Intake Air Temperature Sensor Circuit Low Voltage	0230	Fuel Lock-off Circuit Low Voltage or Open
0113	Intake Air Temperature Sensor Circuit High Voltage or Open	0232	Fuel Lock-off Circuit High Voltage
0117	Coolant/Oil Temperature Sensor Circuit Low Voltage	0336	Crankshaft Position Sensor Noisy Signal
0118	Coolant/Oil Temperature Sensor Circuit High Voltage or Open	0337	Crankshaft Position Sensor No Signal
0122	Throttle Position Sensor Circuit Low Voltage or Open	0351	Cylinder 1 Ignition Coil Malfunction
0123	Throttle Position Sensor Circuit High Voltage	0352	Cylinder 2 Ignition Coil Malfunction
0131	Oxygen Sensor 1 Circuit Low Voltage, or Open	0562	System Voltage Low
0132	Oxygen Sensor 1 Circuit High Voltage	0563	System Voltage High
0171	Maximum Adaptation Limit Exceeded	61	End of Code Transmission

Any changes or modifications to this device that are not expressly approved by the manufacturer may void the user's authority to operate the device.

5.2.9.3 SAFETY INFORMATION

- Read all safety information before using the device to ensure safe and proper use.
- Do not interact with the device while operating your equipment. Doing so may distract your attention and cause an accident or may be illegal depending on your region.
- Avoid any direct contact with pressure washers, water sprayers or cleaning chemicals of any kind.
- Do not drop or cause an impact to the device.
- Do not bend or twist the device and/or wire harness excessively.
- Do not disassemble, modify or repair your device. This product contains no user serviceable parts.

5.3. ELECTRONICS MODULE OF DIGITAL FUEL CONTROL SYSTEM

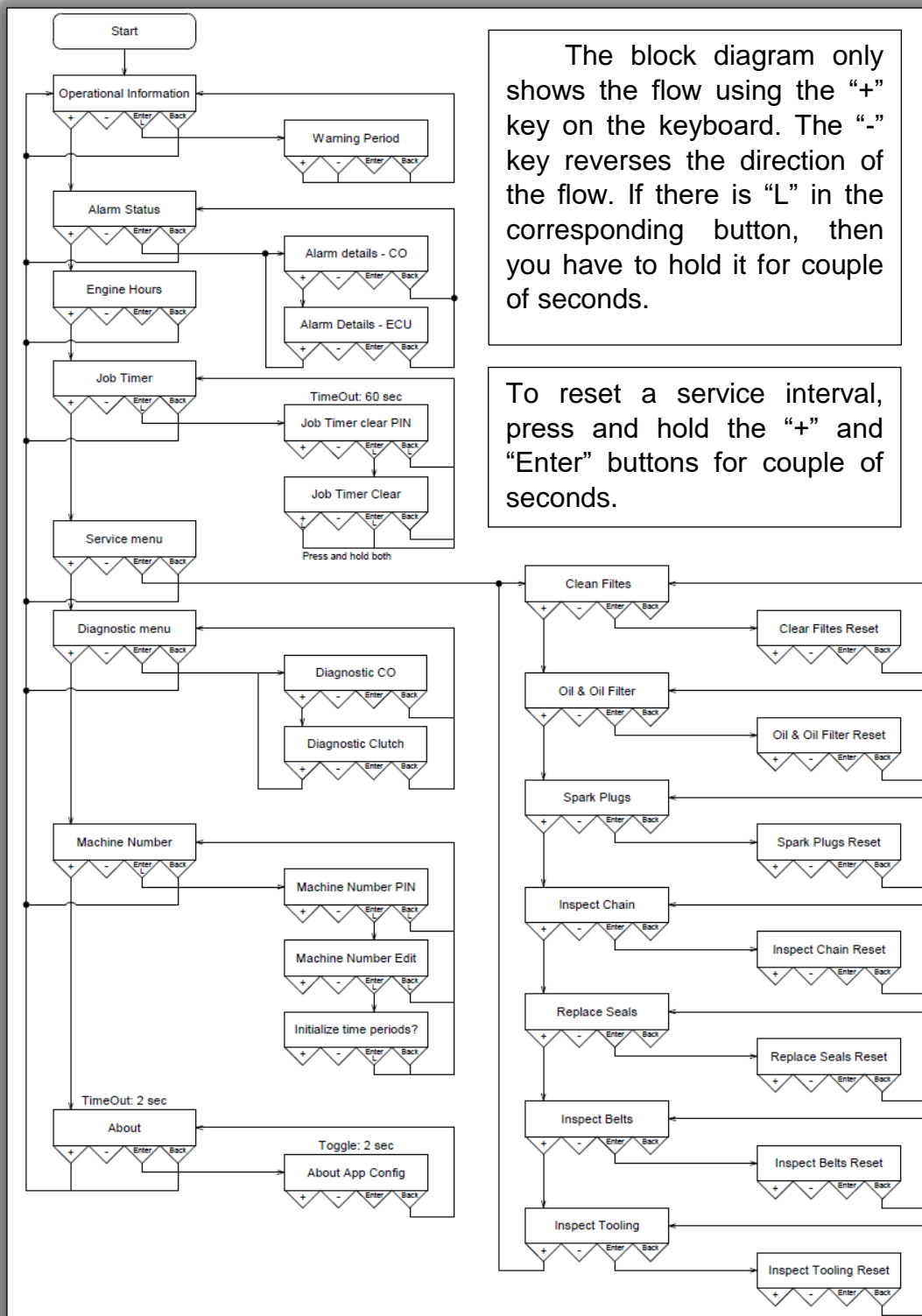

6. OPERATING THE MACHINE



IMPORTANT!!!

The machine has a CO shut-off module installed under the handle. In newer versions of the machine, its located behind the propane tank on the right upper corner. If the CO emissions become dangerous for the operator, the module will shut the machine off.

Always pay attention:

- Everything okay, No LED.
- TWA level alarm, Yellow LED flash every 5 seconds.
- 200 ppm level alarm, Red LED flash every 5 seconds and shutdown the engine.
- Fault, Yellow LED flash every 5 seconds, shutdown engine and buzzer beeps every 60 seconds.



Although the machine has a built in sensor, we recommend that the operator always wears a carbon monoxide indicator badge as an extra precaution.

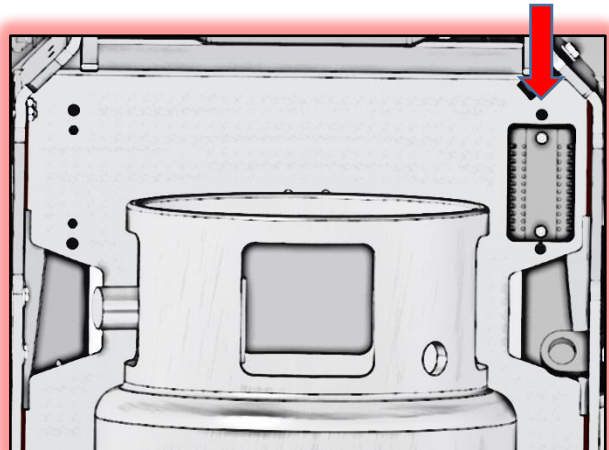
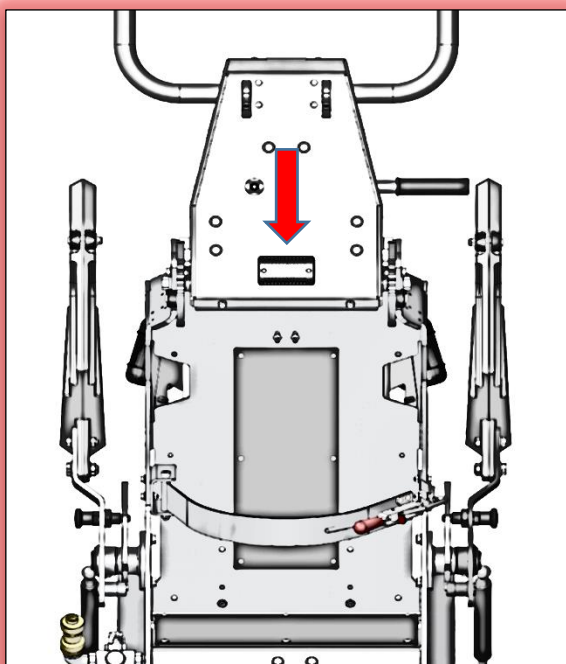

6.1. PROTECTIVE COVER

The protective cover has two straps - one on each side.

The cover is mounted as the straps are screwed to the grinding head by the threaded knob.

Each strap has two holes in it. Depending on which hole the straps are mounted on defines whether the protective cover is mounted in the work or transport position.

If the straps are mounted on the first hole, the cover is in the **working position**.

If the straps are mounted on the second hole, the protective cover is fixed in to the **transport position**. In the transportation position the cover is hanged up so it does not drag on the surface.

To **dismount the protective cover** detach the vacuum hose, unscrew the straps, remove one of the tools holders if your machine has 13" holders if it's with 9" holders, just unscrewing the straps is enough.

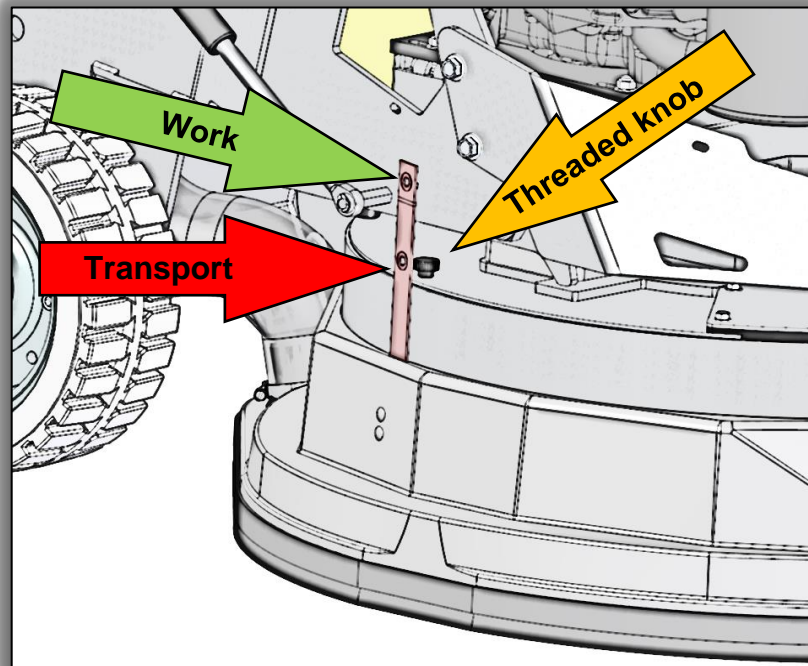

6.2. ADJUSTING THE HANDLE

The machine is equipped with two locking mechanisms – one for rough and one for fine adjustment of the handle position. They provide fast and stable handle adjustment.

Both mechanism work as the lever is pulled towards the operator to unlock and after fixing into the desired position the mechanism locks itself back.

IMPORTANT! If the locking mechanisms start making noises or moves roughly a lubrication with WD-40 or similar lubricant is recommended.

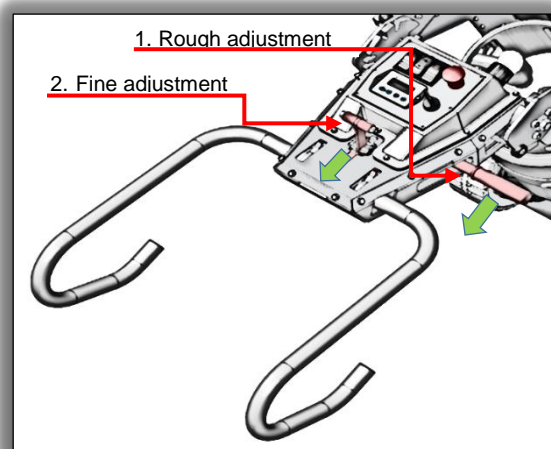

6.3. ADJUSTING THE WEIGHTS

The machine has four weights positions in order to deliver the best grinding pressure for the specific tools.

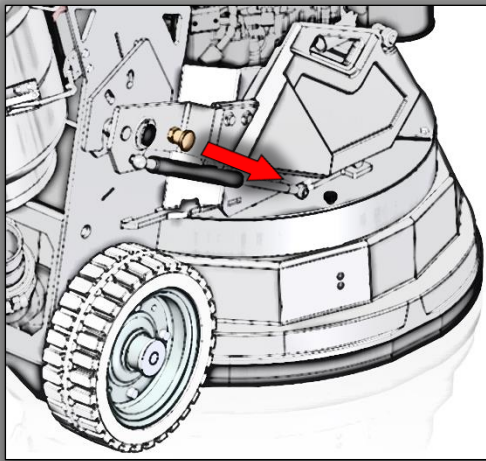
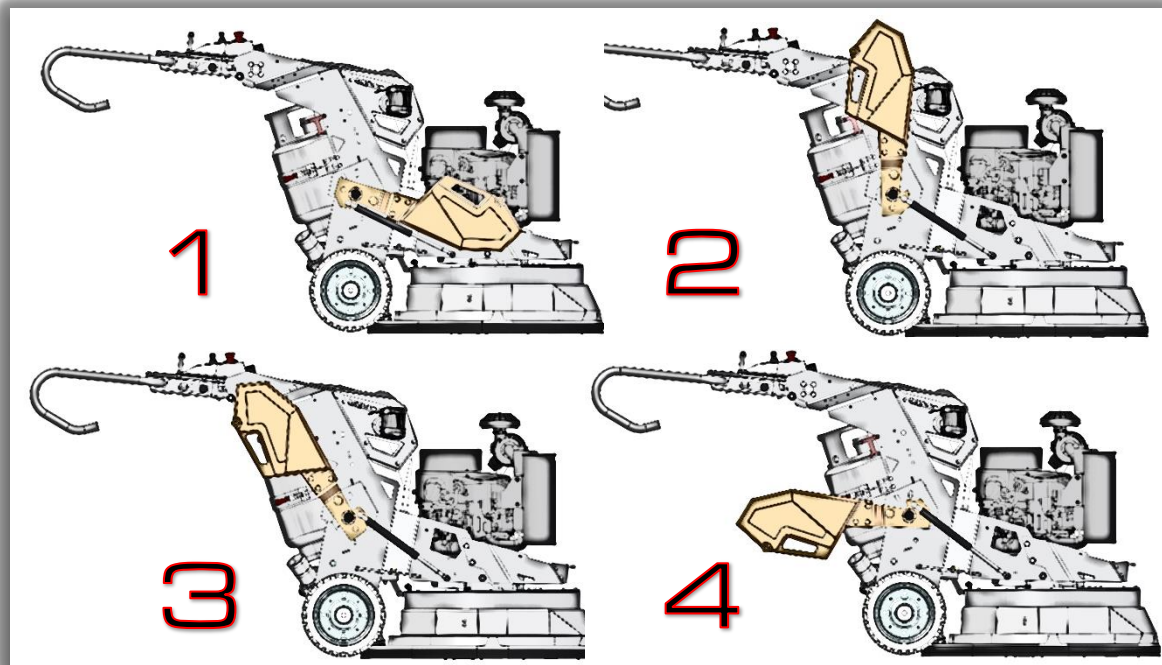

To move the weights release the locking knob by pulling it and then release it to lock into the new desired position.

The locking knob has a **rest position**. Pull it to unlock, rotate the handle to 90 degrees and it will stay fixed in this position leaving the weight free to move in all directions.

In order to flip the machine for tool changes, the weights must be in pos. 4. The operator can step on one of the weights in order to tilt the machine easily.

IMPORTANT!!!

When flipping the machine, the knob must be in rest position.

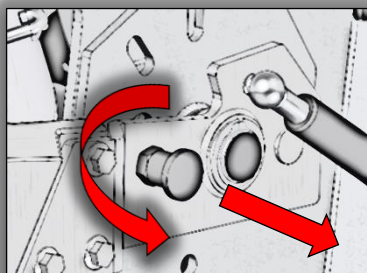

6.4. WATER FEED

The machine is equipped with a three way water tap (1) that provides the operator to choose between the water tank and external hose as a water source. Also a secondary water tap (2) which allows the operator to adjust the water flow level.

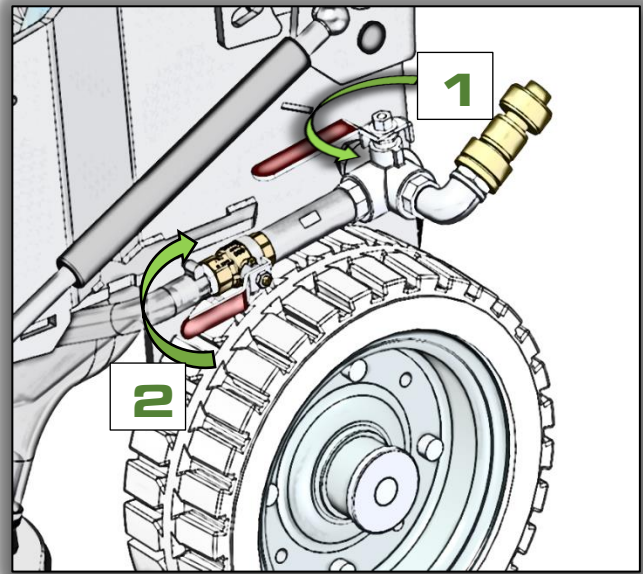
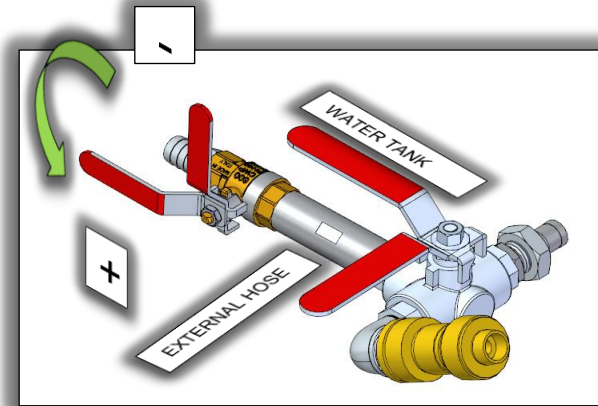

6.5. CONTROL BOARD

- | | |
|---|---------------------------|
| 1 | Start/Stop engine switch |
| 2 | Engage/Disengage clutch |
| 3 | USB port |
| 4 | Lights switch |
| 5 | EMG stop button |
| 6 | Electronic module of DFCS |
| 7 | Throttle controller |

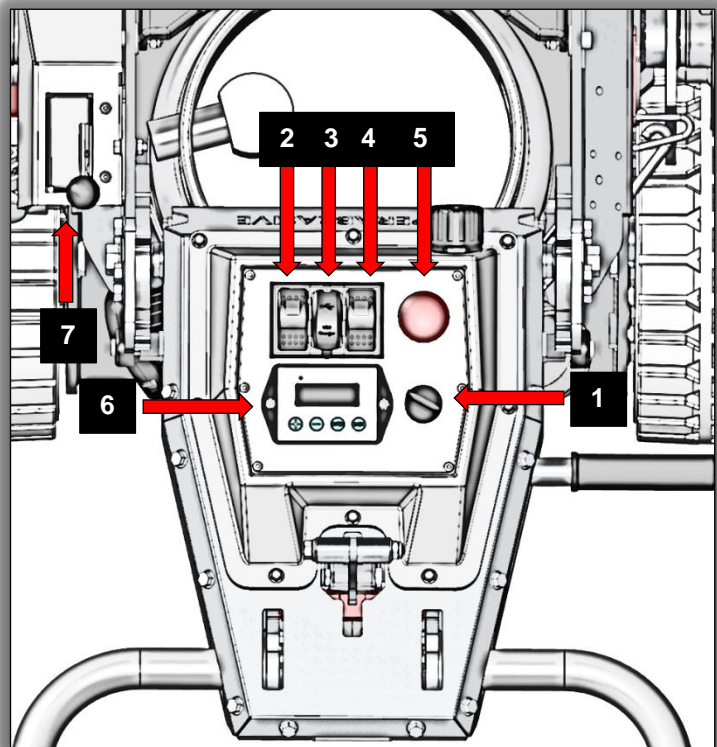

- Start/Stop engine switch – turn the key fully to the right to start the engine. Fully to the left will arrest the engine.
- Engage/Disengage clutch – engages or disengages the clutch which transmits the torque from the engine to the tool holders.
- USB port – can be used as a charger.
- Lights switch – switches the lights on/off.
- Emergency (EMG) stop button – stops the engine in case of emergency.
- Electronic module of digital fuel control system (DFCS) (see [ELECTRONICS MODULE OF DIGITAL FUEL CONTROL SYSTEM](#))
- Throttle controller – increase the engine rpm by pushing it forward.

6.6. MOUNTING TOOLS

Use the tool holder key (1) to rotate the key lock (3) in order to unlock and dismount the security plate (2).

Install tools into the tool holder's nests and by following the steps in reversed order lock install the security plate (2) and lock it.

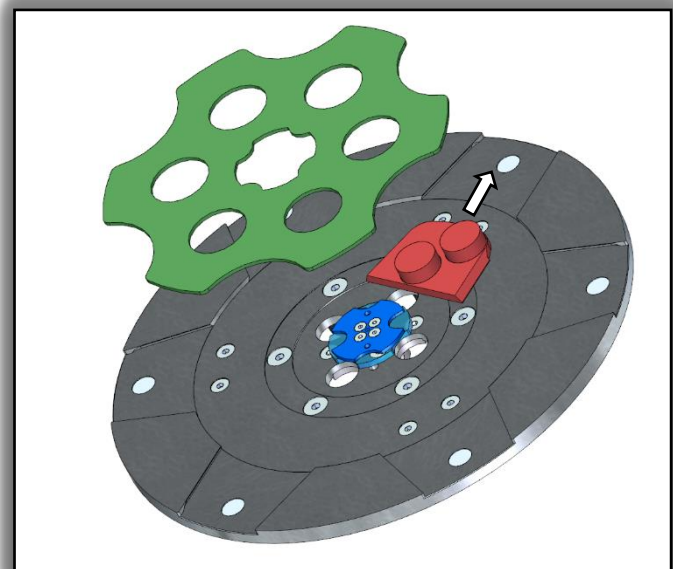
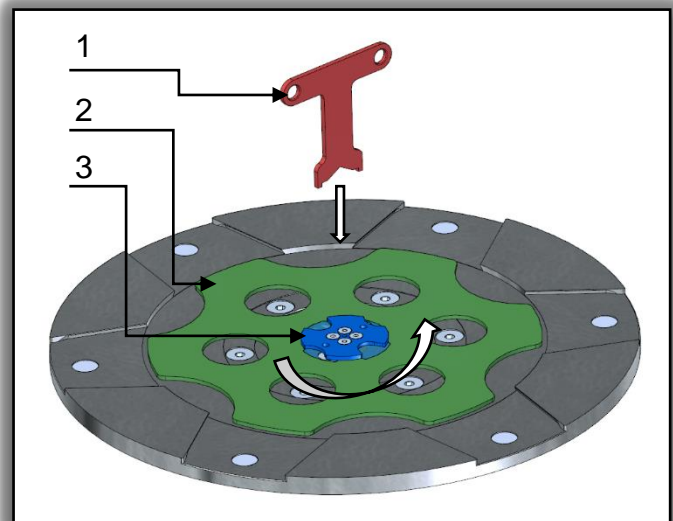

6.7. STARTING THE MACHINE

- First follow the directions in the chapter on safety devices and safety instructions. Check oil level.
- Open the service valve on the propane tank about one and a half (counterclockwise) turns. This creates the necessary vacuum to open the lock-off valve inside the regulator.
- Set the throttle lever to approximately 1/5 of its movement capability.
Note: Don't start the engine at full throttle!
- Proper maintenance will ensure easy starting. Engage start/stop engine switch for maximum 5 to 6 seconds or until the engine fires.
- Serious starter damage will result if this is exceeded and the warranty may not apply.
- Operate the engine at half throttle for approximately two minutes to properly warm engine. Then advance to full throttle for best results.
- If working wet, add water to the floor surface.
- If working dry, connect the machine to a vacuum unit.
- Finally hold the machine firmly and push to clutch button in order to engage the clutch and start working.

6.8. WHILE OPERATING THE MACHINE

Guide the machine in straight lines across the floor, slightly overlapping the previously completed surface with each new line. Work at a constant speed, allowing the tools time to work at a speed appropriate for the tools' grit size. Avoid vibrations. Do not stop the machine while tools are still running as they will mark the surface of the floor. When working wet, select the destination of the water feed with the water tap and periodically to release water onto the floor surface. When working dry, check the floor surface periodically for dust accumulation. Check regularly to see if your vacuum works properly.

6.9. STOPPING THE MACHINE

Stopping of the machine must be done gradually.

To begin, disengage the clutch by pushing the clutch rocker switch and return the throttle controller to the IDLE position. Wait 5-10 seconds. Turn the Start/Stop engine switch fully to the left in order to arrest the engine. Close (clockwise) the service valve on the propane tank.

In case of emergency only press the "Emergency stop button".

When you finish with the machine, store the propane tank outside the building in a secure place away from head or direct sunlight.

7. TOOLS AND ACCESSORIES

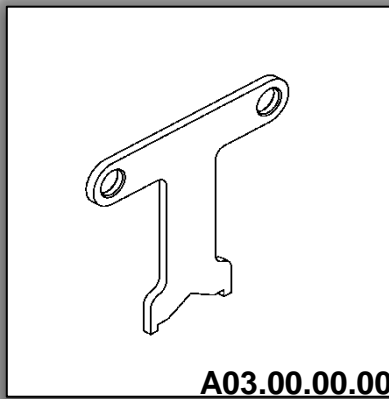

Figure 7.1

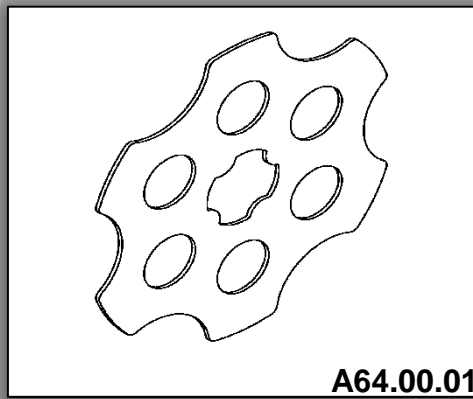

Figure 7.2

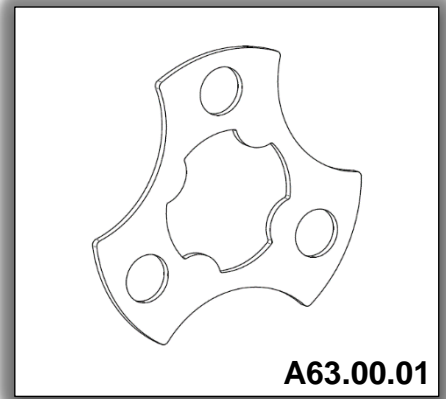

Figure 7.3

- Tool holder key (fig. 7.1) – It is used for mounting and dismounting the security plate.
- Security plate (fig. 7.2) – It is used to secure the “Quickchange” tools. A64.00.01 is for 13” plates.
- Security plate (fig. 7.3) – It is used to secure the “Quickchange” tools. A63.00.01 is for 9” plates.
- Security plate for “Ring tools” A85.00.00 – It is used to ensure the “Ring tools”. Applies only to with 9” plates.
- Support wheel (fig. 7.5) **L30GE02.10.00-1.**

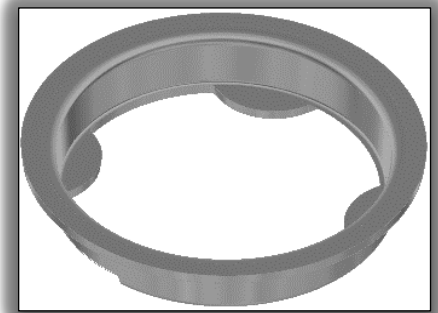

Figure 7.4

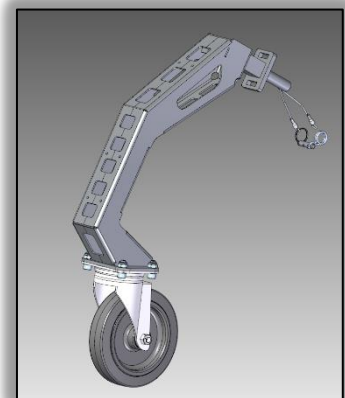

Figure 7.5

- Additional weights – 34kg (fig. 7.6) A114.00.00.

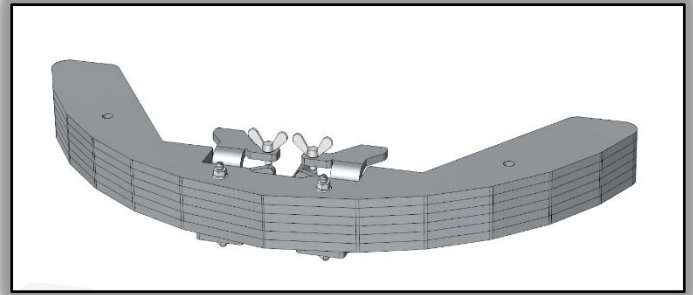
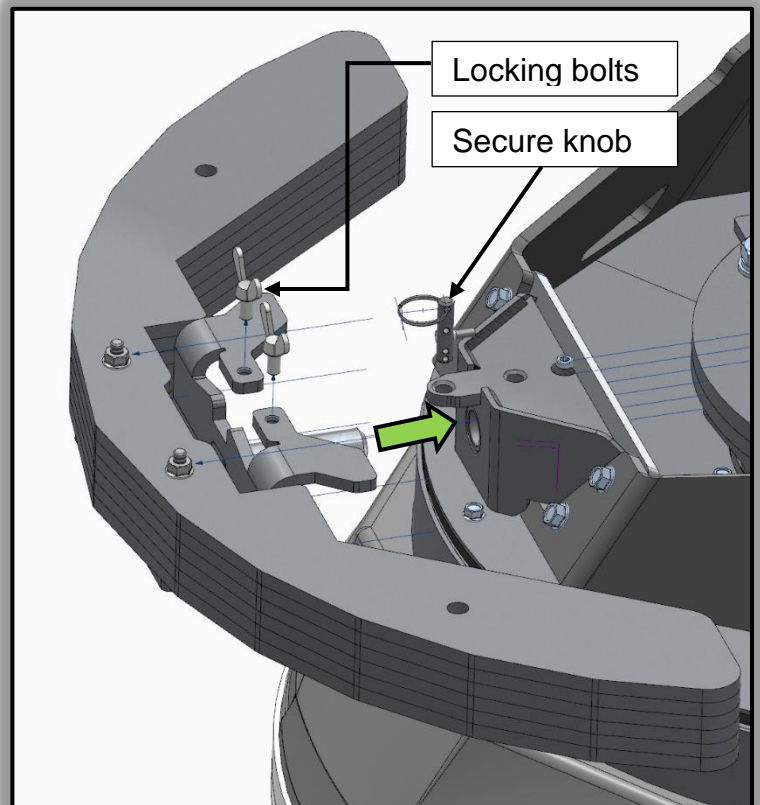

Figure 7.6

To install the additional weights, use the holder for the support wheel.

Once the additional weight is installed on the holder, tighten the locking bolts and place the secure knob.



IMPORTANT!!!

The additional weight can be mounted on each 25 or 30 S7 machine but we recommend to use it only on L30GVS7.

We want to emphasize that if the additional weight is utilized with any other machine apart the L30GVS7, there may be a risk of inadequate engine power.

We cannot be held responsible for any issues related to engine power deficiency.

The L30GVS7 machine has 320kg or 706lbs max grinding pressure with the additional weight.

7.1. RECOMMENDED TOOLS



“Quickchange” system and tooling feature extremely fast and convenient tool changes and a long life, providing for great long-term cost savings.

- The “Quickchange” pads are produced in four different bonds for super hard, hard, medium and soft concrete in a variety of grit sizes. They are offered with one or two buttons or rectangular segments, which allows you to customize the aggressiveness of the cut.



- Corsa Hybrid Discs with “Quickchange” attachment for wet and dry – The new Corsa hybrid discs are designed for scratch removal and transitioning from metal to resin tools. They are similar to Calibra but the ceramic bond has been modified for more efficient use on soft and medium concrete.



- NATO ® with “Quickchange” attachment – Superabrasive’s NATO resin pucks are a great tool choice for soft and hard concrete polishing applications. Among the thickest diamond pads on the market featuring a thick 12mm layer of resin and diamonds for extra-long life. Wide channels and unique patented design allows for work on a cleaner surface, ensuring a quality polish. Offered in wet and dry bond.



- V-HARR® Premium polishing pads now available in “Quickchange” style for 9” and 13” holders. V-HARR felt diamond pads are one of Superabrasive’s most versatile and successful diamond tools for concrete polishing. They are also ideal for polishing terrazzo and hard stone floors. V-HARR polishing pads should be used dry on concrete! However, they will produce remarkable gloss results on black granite when used wet.



- Hybrid and resin tool rings – Exceptional flexibility with a thick layer of flexible foam. Quick and easy magnetic attachment directly to the grinding heads. Offered in 9” and 13”, compatible with Lavina® grinders and trowels.

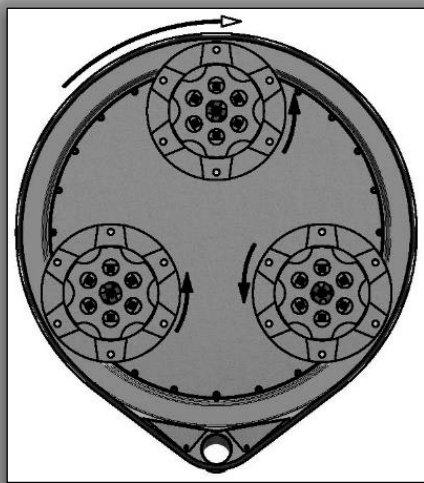

NOTE: The heads have counter-clockwise / left rotation. Use the blue PCDs and Carbide Scrapers

8. MAINTANANCE AND INSPECTION

Tampering with the Emissions control system prohibited.

Federal law and California state law prohibits the following acts or the causing thereof:

- Removal or rendering inoperative by any person other than for purposes of maintenance, repair or replacement of any device or element at design incorporated into any new engine for the purpose of emission control prior to its sale or delivery to the ultimate purchaser or while it is in use.
- The use of the engine after such device or element of design has been removed or rendered inoperative by any person. Among those acts presumed to constitute tampering, involve the parts/systems listed below:
 - Carburetor and internal parts;
 - Spark plugs;
 - Magneto or electronic ignition system;
 - Fuel filter element;
 - Air cleaner elements;
 - Crankcase;
 - Cylinder heads;
 - Breather chamber and internal parts;
 - Intake pipe and tube;

8.1. MECHANICAL PARTS

Parts such as belts, seal rings, cap rings, spiders, buffers, guard assembly, tires are subject to wear and should be replaced if needed.

8.2. CLEANING

Keep your machine clean. Cleaning the machine on a regular basis will help detect and solve potential problems before they cause damage to the machine. Most importantly, check and clean the tool plate connections, vacuum hoses, water tank and the propane installation.

8.3. CHECK DAILY

After operating the machine, the operator should conduct a visual inspection of the machine. Any defect should be fixed immediately. Pay attention to power cords, plugs and vacuum hoses, loose bolts or screws.

8.3.1. TOOL HOLDERS

Buffers and the elastic element are consumable and must be visually checked daily and replaced if needed. Ensure that flanges or discs are mounted and locked well in place. The key lock holders (butterflies) should be also checked.

Check the rubber buffers and fixing of the holders. The flange which hold the buffers (1) has to be firmly fixed to the unit. The screws have to be tightened immediately for safe operation. Working with loose screws on the holder could also cause severe damage on the machine and injuries to the operator. **Tightening torque of the screws must be 22-25Nm or 16-18ft/lbs.**

It is very important to check the screws (2) that fix the "Quickchange" holder to the safety part, so that the holder will not fly away if the buffers are damaged.

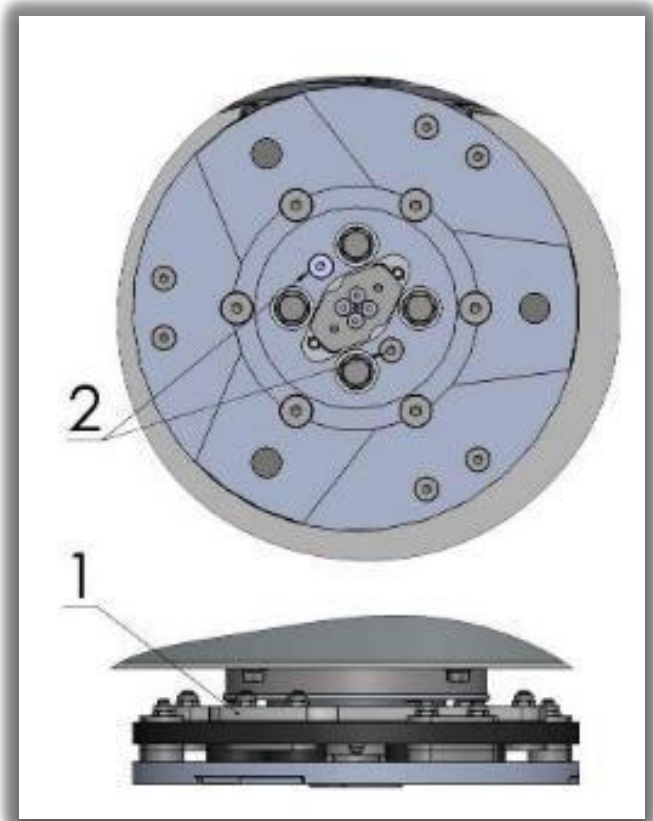

8.4. ENGINE MAINTENANCE

8.4.1. KAWASAKI FX 600

IMPORTANT!!! The engine oil and the oil filter must be changed after the first 8 hours of work. This applies only for the Kawasaki engines.

All the information provided is from the engine’s user manual. It can be found at www.kawasakienginesusa.com

Displacement	603cc (36.8 cu. In.)
Oil capacity with oil filter	1.6 U.S. qt (1.5 liters)
Oil capacity without oil filter	1.8 U.S. qt (1.7 liters)
Max power	19 hp (14.2 kW) at 3600 rpm
Max torque	32.5 ft-lbs (44 Nm) at 2200 rpm
Recommended oil	10W-40 SJ or SL class

MAINTENANCE	INTERVAL					
	Daily	Every 50 hr.	Every 100 hr.	Every 200 hr.	Every 250 hr.	Every 300 hr.
Check and add engine oil.	•					
Check for loose or lost nuts and screws.	•					
Check for fuel and oil leakage.	•					
Check battery electrolyte level.	•					
♦ Check or clean air inlet screen.	•					
Check cleanout cover.		•				
♦ Clean dust and dirt from cylinder and cylinder head fins.			•			
Tighten nuts and screws.			•			
Change engine oil.	Every 50 hours					
Clean and regap spark plugs.			•			
Change oil filter.				•		
♦ Replace air cleaner element					•	
◇ Clean combustion chamber.						•
◇ Check and adjust valve clearance.						•
◇ Clean and lap valve seating surface.						•

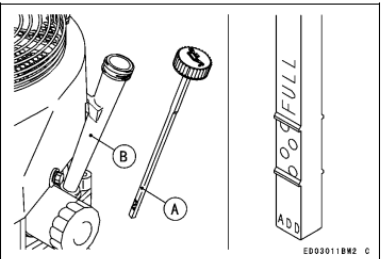
<p>Oil Level Check</p> <p>Check oil level daily and before each time of operation. Be sure oil level is maintained. See "PREPARATION" chapter.</p> <p>Engine Oil Capacity</p> <table border="1"> <tr> <td>FX481V FX541V FX600V</td> <td>1.5 L (1.6 US-qt) [when oil filter is not removed]</td> </tr> <tr> <td></td> <td>1.7 L (1.8 US-qt) [when oil filter is removed]</td> </tr> </table> 	FX481V FX541V FX600V	1.5 L (1.6 US-qt) [when oil filter is not removed]		1.7 L (1.8 US-qt) [when oil filter is removed]	<p>Oil Change</p> <p>Change oil <u>every 100 hours</u> or <u>1 year</u> whichever comes first.</p> <ul style="list-style-type: none"> • Run the engine to warm oil. • Be sure the engine (equipment) is level. • Stop the engine. • Remove the oil drain plug (A) and drain the oil into suitable container while engine is warm. <div style="border: 1px solid black; padding: 5px; text-align: center;"> <p>⚠ WARNING</p> <p>Hot engine oil can cause severe burns. Allow engine temperature to drop from hot to warm level before draining and handling oil.</p> </div> <ul style="list-style-type: none"> • Replace the O-ring of the oil drain plug with a new one. • Apply grease to the O-ring. • Tighten the oil drain plug. <p>Tightening Torque</p> <div style="border: 1px solid black; padding: 5px;"> <p>Oil Drain Plug: 6.9 N·m (0.70 kgf·m, 61 in·lb)</p> </div> <ul style="list-style-type: none"> • Remove oil gauge and refill with fresh oil (See "FUEL AND OIL RECOMMENDATIONS" chapter). • Check the oil level (See "PREPARATION" chapter for oil level check).
FX481V FX541V FX600V	1.5 L (1.6 US-qt) [when oil filter is not removed]				
	1.7 L (1.8 US-qt) [when oil filter is removed]				

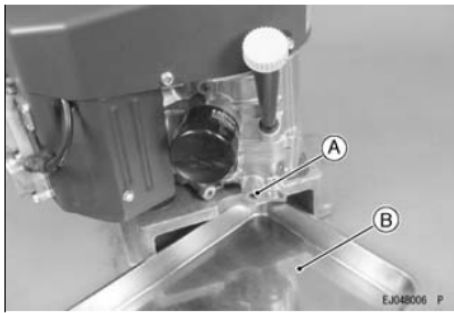

A. Oil Drain Plug
B. Suitable Container

WARNING

Engine oil is a toxic substance. Dispose of used oil properly. Contact your local authorities for approved disposal methods or possible recycling.

Oil Filter Change

- Change the oil filter every 200 hours of operation.

WARNING

Hot engine oil can cause severe burns. Allow engine temperature to drop from hot to warm level before attempting to remove oil filter.

- Drain engine oil into a suitable container.

NOTICE

Before removing the oil filter, place suitable pan under filter connection.

- Rotate the oil filter (A) counterclockwise to remove it.
- Coat a film of clean engine oil on seal of new filter.
- Install new filter rotating it clockwise until seal contacts mounting surface (B). Then rotate filter 3/4 turn more by hand.
- Supply engine oil as specified.
- Run the engine for about 3 minutes, stop engine, and check oil leakage around the filter.
- Add oil to compensate for oil level drop due to oil filter capacity (See "PREPARATION" chapter for oil level check).

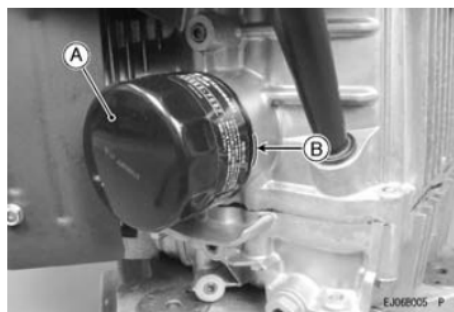

A. Oil Filter
B. Mounting Surface

WARNING

Engine oil is a toxic substance. Dispose of used oil properly. Contact your local authorities for approved disposal methods or possible recycling.

Air Cleaner Service

Heavy Duty Air Cleaner

These air cleaner elements are not recommended to be cleaned. Replace each air cleaner element with a new one at the maintenance time as shown in the maintenance chart.

NOTICE

To prevent excessive engine wear, do not run the engine with the air cleaner removed.

NOTICE

Do not wash air cleaner elements.
Do not oil air cleaner elements.
Do not use pressurized air to clean air cleaner elements.

NOTE

- Operating in dusty condition may require more frequent maintenance.

Air Cleaner Element

Replace the air cleaner element every 250 hrs.

Cap (Dust Ejector Valve)

Push and open the cap (C) on the case of the air cleaner body to expel dust and/or water accumulated inside.

- Unfasten the two retaining clamps (A) and remove the case (B) from the air cleaner body (D).
- Remove the air cleaner element (E) from the air cleaner body by pulling out them.

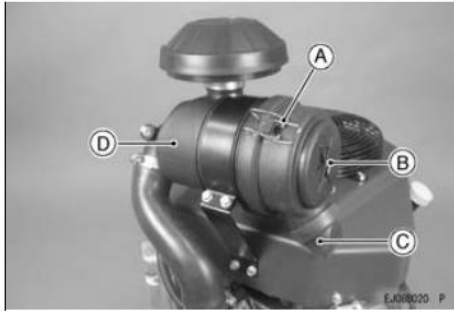

A. Retaining Clamps
 B. Case
 C. Cap (Dust Ejector Valve)
 D. Air Cleaner Body

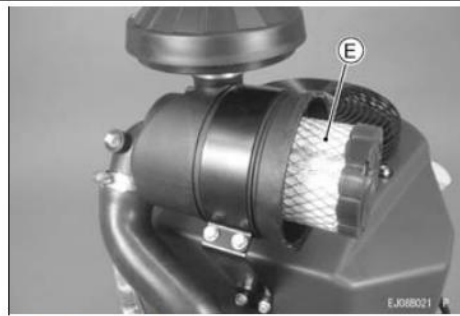

E. Air Cleaner Element

- Install the new air cleaner element into the air cleaner body.
- Reinstall the case and the cap (C) then securely fasten the two retaining clamps.

Spark Plug Service

⚠ WARNING

Engines can become extremely hot during normal operation. Hot engine components can cause severe burns. Stop the engine and allow it to cool before checking spark plugs.

Clean or replace the spark plugs and reset spark plug gap (A) every 100 hours of operation.

- Disconnect the spark plug caps from the spark plugs and remove the spark plugs.
- Clean the electrodes (B) by scraping with a wire brush to remove carbon deposits.
- Inspect for cracked porcelain or other wear and damage. Replace the spark plug with a new one if necessary.
- Check the spark plug gap and reset if necessary. The gap must be 0.75 mm (0.030 in). To change the gap, bend only the side-electrode, using a spark plug tool.
- Install and tighten the spark plugs to 22 N·m (2.2 kgf·m, 16 ft·lb). Connect the spark plug caps.

RECOMMENDED SPARK PLUG
 NGKBPR4ES

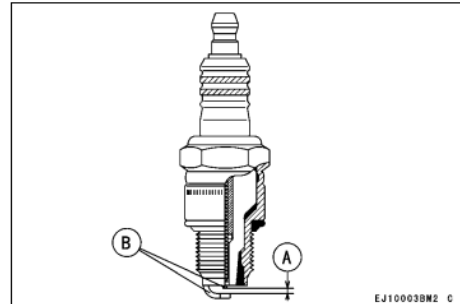

A. Spark Plug Gap
 B. Electrodes

8.4.1.1 ELECTRICAL DIAGRAM

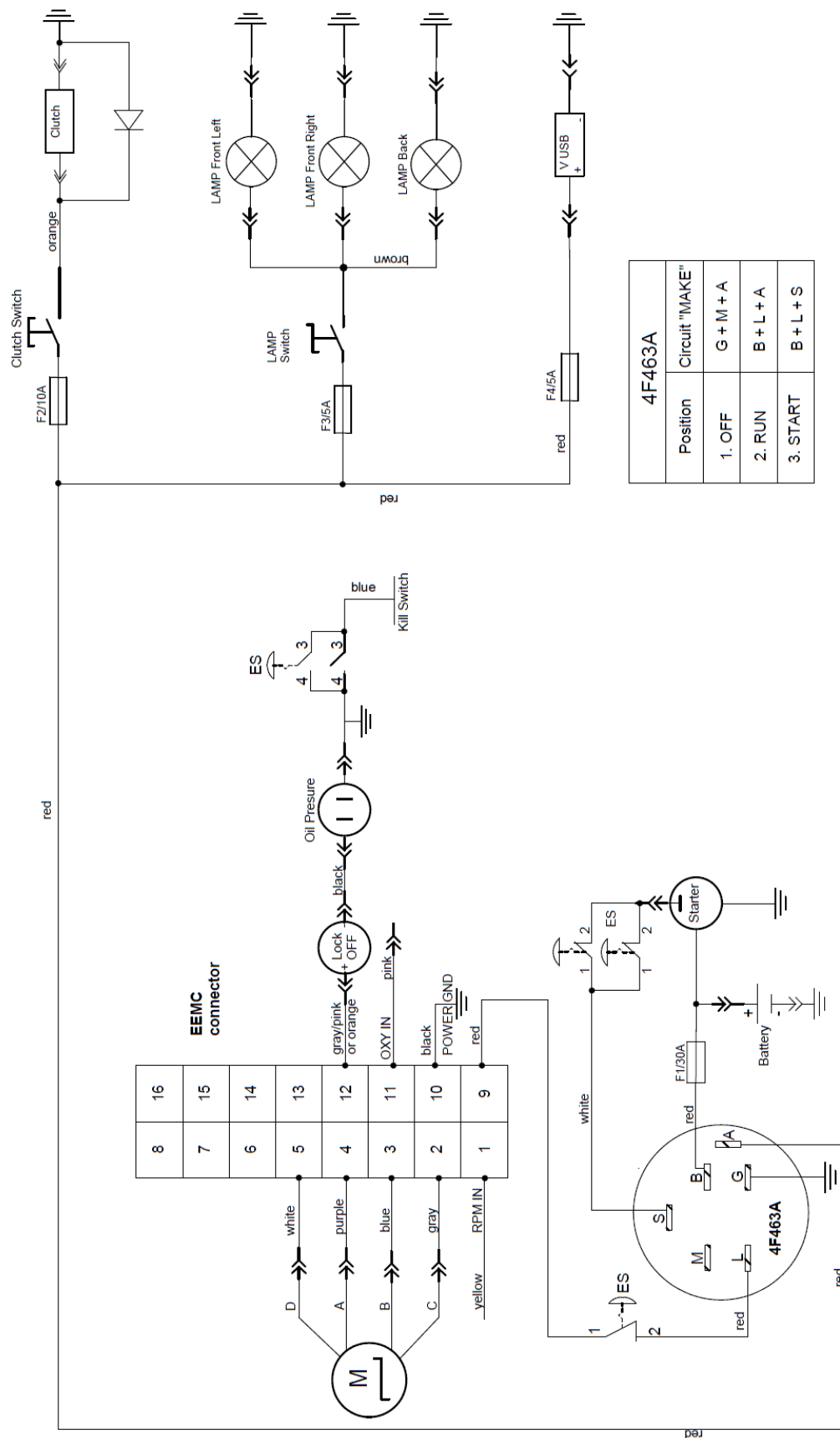

8.4.2. KOHLER PCV740

All the information provided is from the engine’s user manual. It can be found at www.kohlerpower.com

Displacement	747cc (45 cu. In.)
Oil capacity	1.9 U.S. qt (2 liters)
Power	24 hp (17 kW)
Gross torque	37.3 ft-lbs (50.6 Nm)
Recommended oil	KOHLER PRO 10W-50

MAINTENANCE SCHEDULE	
Every 25 Hours¹	
• Service/replace low-profile precleaner (if equipped).	Air Cleaner/Intake
Every 100 Hours¹	
• Check oil cooler fins, clean as necessary (if equipped).	Air Cleaner/Intake
• Change oil.	Lubrication System
• Replace low-profile air cleaner element (if equipped).	Air Cleaner/Intake
• Remove cooling shrouds and clean cooling areas.	Air Cleaner/Intake
Every 150 Hours¹	
• Check heavy-duty filter minder.	Air Cleaner/Intake
• Inspect heavy-duty air filter paper element and inlet screen area.	Air Cleaner/Intake
Every 200 Hours	
• Change oil filter.	Lubrication System
• Replace unique EFI fuel filters.	
Every 300 Hours¹	
• Replace heavy-duty air cleaner element and check inner element.	Air Cleaner/Intake
Every 300 Hours³ (Not available for PCV680LE, PCV740LE engine models)	
• Change oil and filter (KOHLER PRO 10W-50 oil and KOHLER PRO filter only).	Lubrication System
Every 500 Hours or Annually¹	
• Check all lines (high pressure/vacuum) including fittings for leaks.	Fuel System
• Drain vaporizer/regulator of accumulated fuel deposits.	Fuel System
• Replace spark plugs and set gap.	Electrical System
Every 500 Hours or Annually^{1,2}	
• Inspect lock-off assembly for damage/leakage.	Fuel System
Every 600 Hours or Annually¹	
• Replace heavy-duty air cleaner inner element.	Air Cleaner/Intake
Every 1500 Hours^{1,2}	
• Have vaporizer/regulator tested.	Fuel System

¹ Perform these procedures more frequently under severe, dusty, dirty conditions.
² Must be performed by a Kohler authorized dealer or qualified propane personnel only.
³ Option only if using KOHLER® PRO oil and PRO oil filter.

Oil Recommendations

Synthetic oil is recommended for use in propane fueled engines. Non-synthetic oil must be low ash* rated oil. Oils (including synthetic) must meet API (American Petroleum Institute) service class SG, SH, SJ, or SL. Select viscosity based on air temperature at time of operation as shown in table below.

*Low ash is defined as less than 1% sulfated ash.

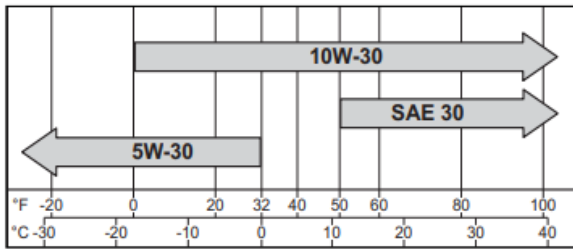

Check Oil Level

NOTE: To prevent extensive engine wear or damage, never run engine with oil level below or above operating range indicator on dipstick.

Ensure engine is cool. Clean oil fill/dipstick areas of any debris.

1. Remove dipstick; wipe oil off.
 - a. Press-in cap: reinsert dipstick into tube; press completely down.
 - or
 - b. Thread-on cap: reinsert dipstick into tube; rest cap on tube, do not thread cap onto tube.
2. Remove dipstick; check oil level. Level should be at top of indicator on dipstick.
3. If oil is low on indicator, add oil up to top of indicator mark.
4. Reinstall and secure dipstick.

Change Oil and Filter

Change oil while engine is warm.

1. Clean area around oil fill cap/dipstick and drain plug. Remove drain plug and oil fill cap/dipstick. Allow oil to drain completely.
2. Clean area around oil filter. Place a container under filter to catch any oil and remove filter. Wipe off mounting surface. Reinstall drain plug. Torque to 10 ft. lb. (13.6 N·m).
3. Place new filter in shallow pan with open end up. Fill with new oil until oil reaches bottom of threads. Allow 2 minutes for oil to be absorbed by filter material.
4. Apply a thin film of clean oil to rubber gasket on new filter.
5. Refer to instructions on oil filter for proper installation.
6. Fill crankcase with new oil. Level should be at top of indicator on dipstick.
7. Reinstall oil fill cap/dipstick and tighten securely.
8. Start engine; check for oil leaks. Stop engine; correct leaks. Recheck oil level.
9. Dispose of used oil and filter in accordance with local ordinances.

Oil Sentry™ (if equipped)

This switch is designed to prevent engine from starting in a low oil or no oil condition. Oil Sentry™ may not shut down a running engine before damage occurs. In some applications this switch may activate a warning signal. Read your equipment manuals for more information.

Air Cleaner

NOTE: Operating engine with loose or damaged air cleaner components could cause premature wear and failure. Replace all bent or damaged components.

NOTE: Paper element cannot be blown out with compressed air.

Low-Profile

Loosen knob and remove air cleaner cover.

Precleaner:

1. Remove precleaner from paper element.
2. Replace or wash precleaner in warm water with detergent. Rinse and allow to air dry.
3. Saturate precleaner with new engine oil; squeeze out excess oil.
4. Reinstall precleaner over paper element.

Paper Element:

1. Clean area around element. Remove wing nut, element cover, and paper element with precleaner.
2. Separate precleaner from element; service precleaner and replace paper element.
3. Check condition of rubber seal and replace if necessary.
4. Install new paper element on base; install precleaner over paper element; reinstall element cover and secure with wing nut.

Reinstall air cleaner cover and secure with knob.

Heavy-Duty

1. Unhook retaining clips and remove end cap(s).
2. Check and clean inlet screen (if equipped).
3. Pull air cleaner element out of housing and replace. Check condition of inner element; replace when dirty.
4. Check all parts for wear, cracks, or damage, and that ejector area is clean.
5. Install new element(s).
6. Reinstall end cap(s) with dust ejector valve/screen down; secure with retaining clips.



Breather Tube (if equipped)

Ensure end of breather tube is properly connected.

Oil Cooler (if equipped)

1. Clean fins with a brush or compressed air.
2. Remove two screws securing oil cooler, and tilt to clean back side.
3. Reinstall oil cooler.

Air Cooling

	 WARNING
	<p>Hot Parts can cause severe burns.</p> <p>Do not touch engine while operating or just after stopping.</p>
<p>Never operate engine with heat shields or guards removed.</p>	

Proper cooling is essential. To prevent over heating, clean screens, cooling fins, and other external surfaces of engine. Avoid spraying water at wiring harness or any electrical components. See Maintenance Schedule.

Repairs/Service Parts

We recommend that you use a Kohler authorized dealer for all maintenance, service, and engine parts. To find a Kohler authorized dealer visit KohlerEngines.com or call 1-800-544-2444 (U.S. and Canada).

Leakage Check/Testing

With fuel valve fully opened, engine not running, turn key switch ON. Check all fuel system connections and lines for leaks using soapy water. Any leakage must be corrected before restarting engine. Have service performed by a Kohler authorized dealer or qualified propane personnel only.

Storage

If engine will be out of service for 2 months or more follow procedure below.

1. Change oil while engine is still warm from operation. Remove spark plug(s) and pour about 1 oz. of engine oil into cylinder(s). Replace spark plug(s) and crank engine slowly to distribute oil.
2. Disconnect negative (-) battery cable.
3. Separate propane tank from unit and store separately in an area designated for safe propane tank storage.
4. Store engine in a clean, dry place.

8.4.2.1 ELECTRICAL DIAGRAM

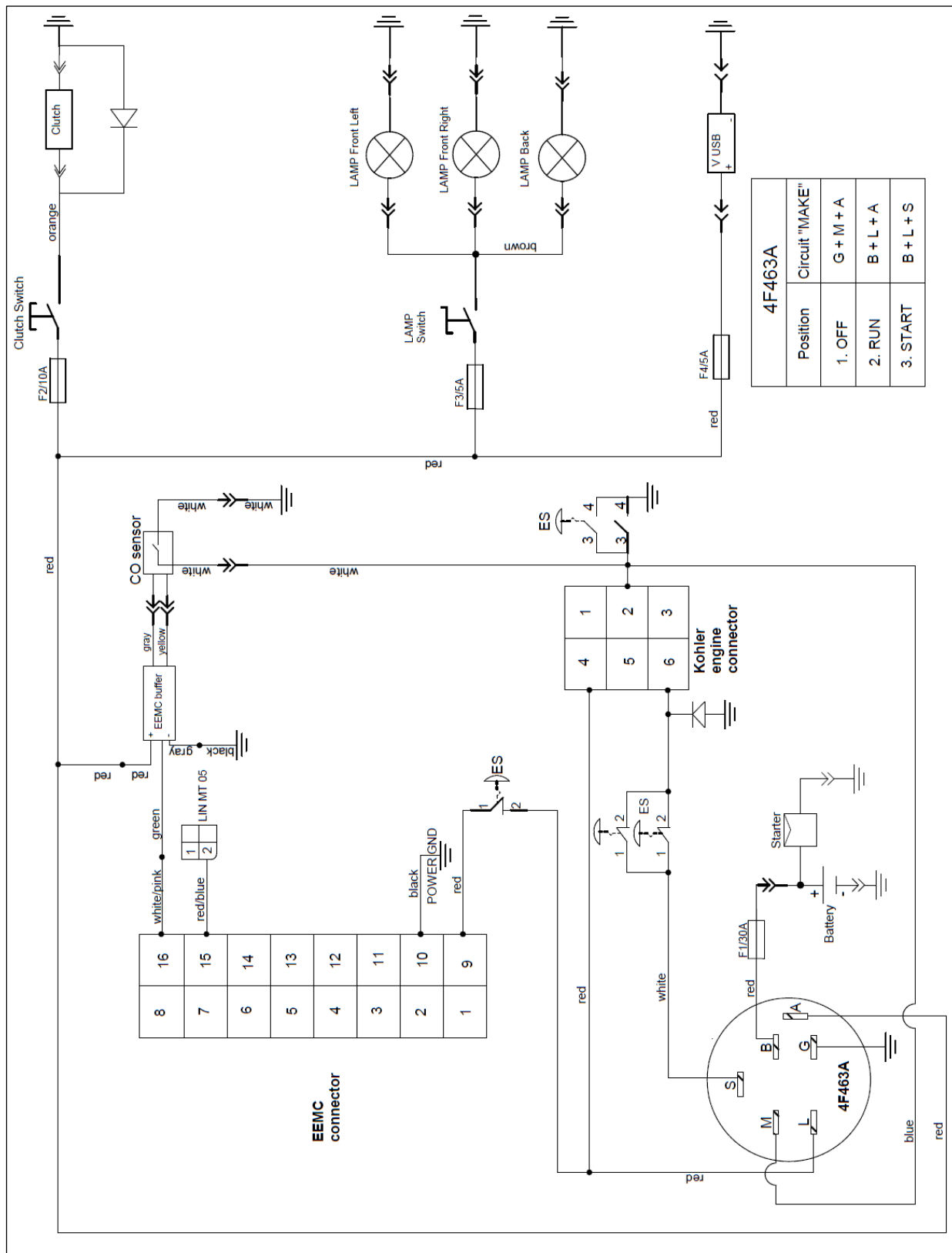

8.4.3. VANGUARD 993CC

All the information provided is from the engine’s user manual. It can be found at www.vanguardpower.com

Displacement	993cc (60.6 cu. In.)
Oil capacity	2.5 U.S. qt (2.4 liters)
Power	35 hp (26 kW)
Recommended oil	5W-30

Maintenance Schedule	
Every 8 Hours or Daily	
<ul style="list-style-type: none"> • Check engine oil level • Clean area around muffler and controls 	
Every 100 Hours or Annually	
<ul style="list-style-type: none"> • Replace spark plugs • Change engine oil • Replace oil filter (if equipped) • Clean or change air filter ^{1,2} • Clean pre-cleaner (if equipped) ¹ • Service exhaust system 	
Every 250 Hours	
<ul style="list-style-type: none"> • Check valve clearance. Adjust if necessary. 	
Every 400 Hours or Annually	
<ul style="list-style-type: none"> • Replace air filter ² • Replace fuel filter • Service cooling system ¹ • Clean oil cooler fins ¹ 	

Operation
<p>Oil Recommendations</p> <p>Oil Capacity: See the <i>Specifications</i> section.</p> <p>NOTICE This engine was shipped from Briggs & Stratton without oil. Equipment manufacturers or dealers may have added oil to the engine. Before you start the engine for the first time, make sure to check the oil level and add oil according to the instructions in this manual. If you start the engine without oil, it will be damaged beyond repair and will not be covered under warranty.</p> <p>We recommend the use of Briggs & Stratton Warranty Certified oils for best performance. Other high-quality detergent oils are acceptable if classified for service SF, SG, SH, SJ or higher. Do not use special additives.</p> <p>Outdoor temperatures determine the proper oil viscosity for the engine. Use the chart to select the best viscosity for the outdoor temperature range expected. Engines on most outdoor power equipment operate well with 5W-30 Synthetic oil. For equipment operated in hot temperatures, Vanguard™ 15W-50 Synthetic oil provides the best protection.</p>

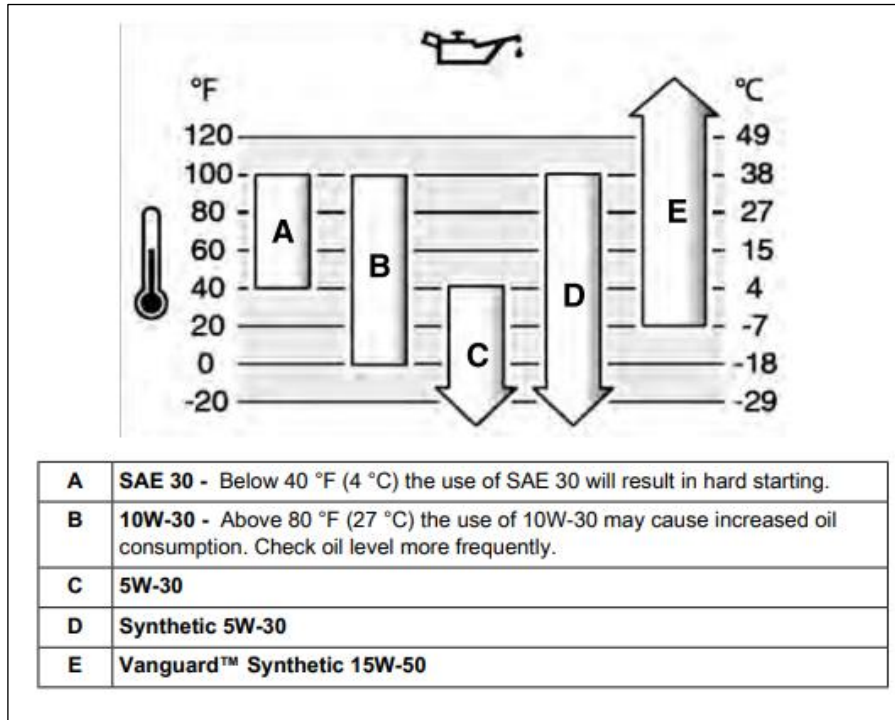

Check Oil Level

See Figure: 5

Before adding or checking the oil

- Make sure the engine is level.
 - Clean the oil fill area of any debris.
1. Remove the dipstick (A, Figure 5) and wipe with a clean cloth.
 2. Fully install the dipstick (A, Figure 5).
 3. Remove the dipstick and check the oil level. Correct oil level is at the top of the full indicator (B, Figure 5) on the dipstick.
 4. If oil level is low, slowly add oil into the engine oil fill (C, Figure 5). **Do not overfill.** After adding oil, wait one minute and then recheck the oil level.
 5. Fully install the dipstick (A, Figure 5).

8.4.3.1 ELECTRICAL DIAGRAM

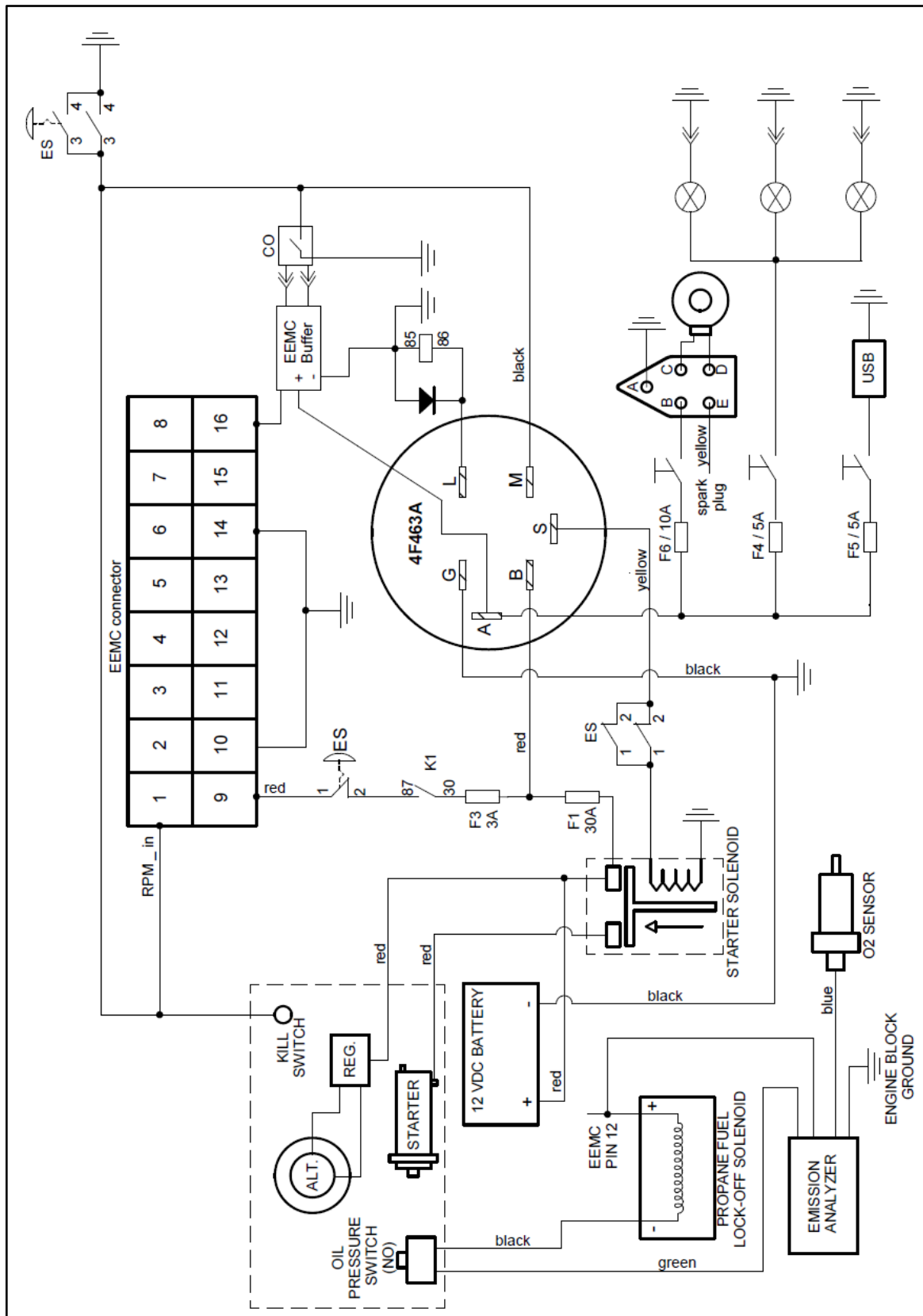

8.5. QUICK ENGINE TROUBLESHOOTING GUIDE

ISSUE OR SYMPTOM	POSSIBLE CAUSE	CORRECTIVE ACTION
ENGINE DOES NOT START	No gas in the tank.	Replace the gas tank. Check fuel hose & regulator.
	No spark.	Check engine service manual.
	No battery power.	Charge the battery, replace if necessary.
	Switch defective	Replace

NOTE: If the given corrective actions do not help or another problem occurs, please check the engine's manual.

8.6. OVERALL MAINTENANCE

OPERATION	INTERVAL							
	Daily	First 8 Hrs.	Every 50 Hrs.	Every 100 Hrs.	Every 200 Hrs.	Every 300 Hrs.	Every 400 Hrs.	Every 500 Hrs.
Check & add engine oil	X							
Check for loose or lost fasteners	X							
Check for oil leakage	X							
Inspect fuel hose and connections	X							
Clean engine dust filter	X							
Inspect throttle & wire	X							
Inspect battery and battery connections				X				
Inspect power cords, plugs and vacuum hoses, loose bolt or screws.	X							
Check the rubber buffers, elastic element and fixing of the holders	X							
Inspect and clean the tool plate connections					X		X	
Inspect and clean water tank.					X		X	
Inspect the seal rings and bearings of the grinding units					X			
Check the planetary chain for any damage								X
Lubricate the planetary chain (only for variations with chain tensioner)					X			
Replace Felt-Ring and V-rings					X			
Check belts and bearings								X
Check the ROTEX clutch plastic element for weariness						X		
* Return machine to authorized service center for overall checkup of the Engine. For Propane safety, have the machine serviced by a Certified Technician, including emission check.								

9. TROUBLESHOOTING

9.1. ENGINE

When troubles occur, be sure to check the simple causes which at first, may seem too obvious to be considered. For example, a starting problem could be caused by fuel starvation due to an empty propane cylinder or an unopened service valve. If you do not check for this, starter burnout could result.

Some troubles and solutions:

Surging idle:

To smooth out the engines' idle characteristics, adjustment is provided by an idle screw on the lower left side of the carburetor as viewed from the operator's position. The screw is bright steel and 1/4" in diameter with a Phillips head on it. Rotating the screw clockwise will increase the idle speed and this should cure the "surging idle". If it does not, call our customer service.

Engine starts and idles, but will quit as the throttle is advanced

It is possible that the propane tank's service valve is faulty. To check for this, close the valve completely and then reopen very slowly while you listen for a "click" when the gas begins to travel through the valve. If you hear this very slight noise, the valve is only partially opening. This allows enough gas through to start and idle the engine, but not enough for full throttle operation. As the throttle is increased, allowing more air to enter the intake, the engine will quit from fuel starvation. Call your dealer or the factory for instructions on where to have the service valve replaced. Meanwhile, to get by, you can continue to open the service valve until you do not hear a "click" and then the engine will run normally. If it does not, call your customer service.

Starter barely turns the engine over or the solenoid just clicks

The battery is likely low in charge. This can be remedied by recharging the battery using a 12 Volt battery charger at 4.12

amperes. The battery is located on the left side of the propane tank holder under the battery cover. The positive post is the one with the RED cable attached to it. Follow the instructions that came with the battery charger. REMINDER: this will continue to happen unless your engine is run for sufficient time between starts to recharge the battery.

9.2. SEPARATING THE CARRIAGE FROM THE GRINDING HEAD

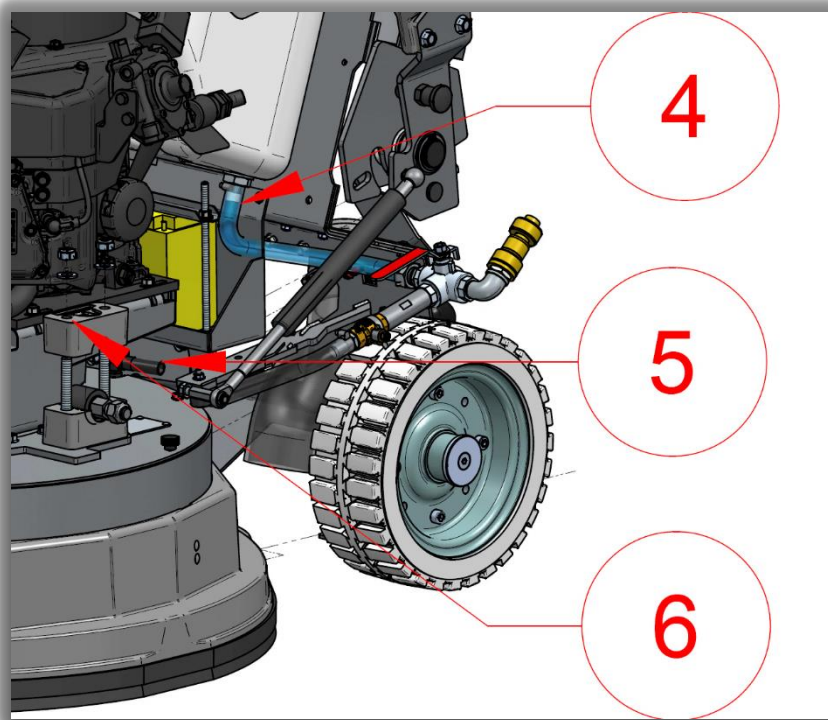
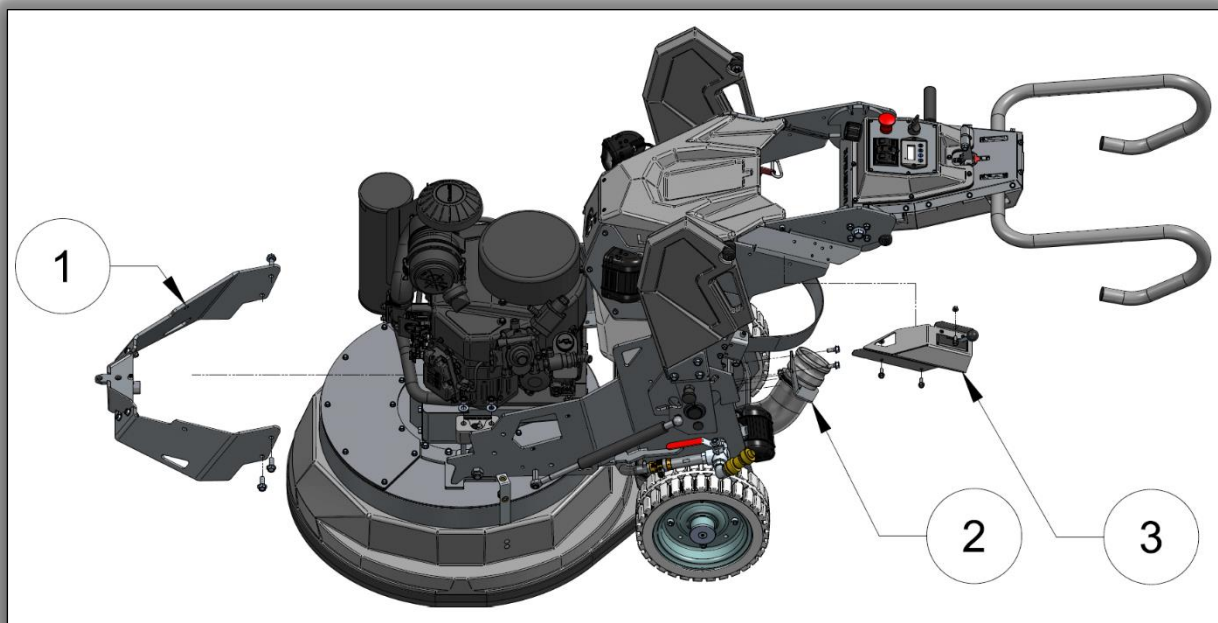

To separate the grinding head from the carriage of the machine follow the steps:

- Unscrew and dismount the front bumper of the machine (1).
- Detach the vacuum hose. It can be done by either removing the hose from the protective cover of the grinding head, or by unscrewing and dismounting the plate which holds the CAMLOCK connector (2).
- Unscrew and dismount the throttle controller with its base plate (3).
- Detach the water supply hoses (4) and (5).
- Disconnect the harness of the engine and the clutch.
- Last step to do is to unscrew both plastic holders based on both sides of the grinding heads (6) and the carriage can be separated from the grinding head.

IMPORTANT!!! It is highly recommended to consult the torque requirement table prior to conducting any maintenance activities to prevent potential complications and ensure optimal performance. Adhering to this protocol can assist in maintaining the reliability and longevity of the equipment in question. It is therefore strongly advised to prioritize the reference of the torque requirement table when planning and executing any maintenance procedures.

BOLT/SCREW SIZE	TORQUE STEEL (Nm)				TORQUE ALUMINUM (Nm)
	5.8	8.8	10.9	12.5	
GRADE					ALL
M6	5.6	9.9	14	16.5	8
M8	13.6	24	34	40	20
M10	27	48	67	81	30
M12	47	83	117	140	

9.3. ENGINE DRIVE

9.3.1. REPLACING THE BELT

To change the belt follow the steps bellow:

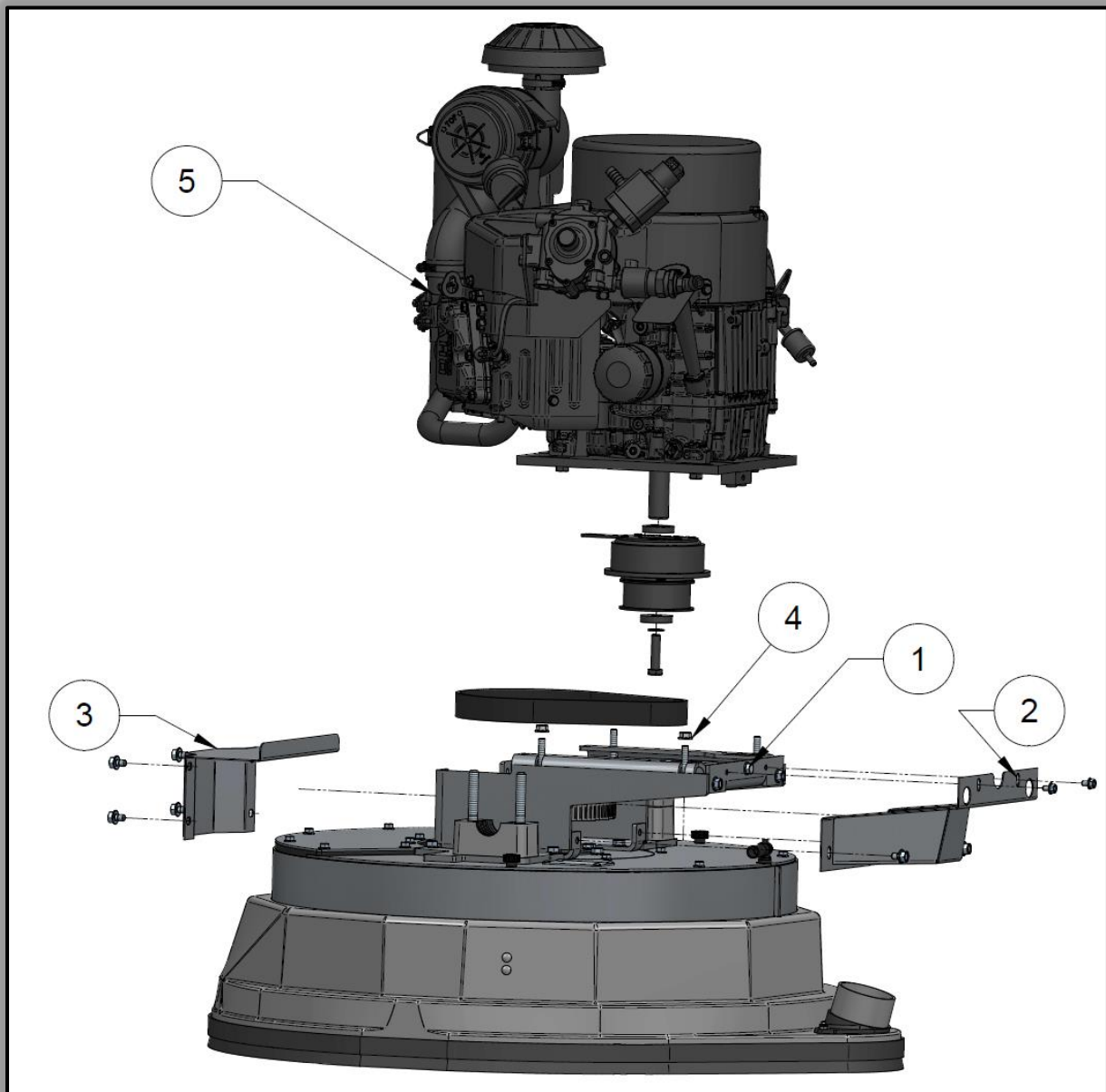

- Dismount the covers (pos. 2 and 3) by unscrewing the bolts which are holding them.
- Loosen the four nuts which are holding the engine's base plate (4).
- Unscrew the bolt pos. (1) and loosen the existing belt.
- Push the engine in the direction of the central pulley and remove the belt.
- In the Vanguard models, to mount the new belt you must lift the engine a bit.
- Install the new belt.

- Once the new belt is installed, screw the four nuts pos. (4) by leaving 1-2mm between the nuts and the engine base plate in order to avoid tilting the engine while tensioning the new belt. To tension the new belt screw the bolt (pos. 1). **The belt can be also tensioned by using frequency tension tester (Optibelt 3 TT). Tension must be 213 - 229 Hz.**
- Once the new belt is installed and tensioned, tighten the nuts pos. (4).
- Mount the covers (pos. 2 and 3).

IMPORTANT!!! NEVER “OVER” TENSION THE BELT, THE BELT WILL BE DESTROYED AND IT WILL NEVER RECOVER ITS ORIGINAL TENSION

9.3.2. CHANGING THE CENTRAL PULLEY OR THE CLUTCH

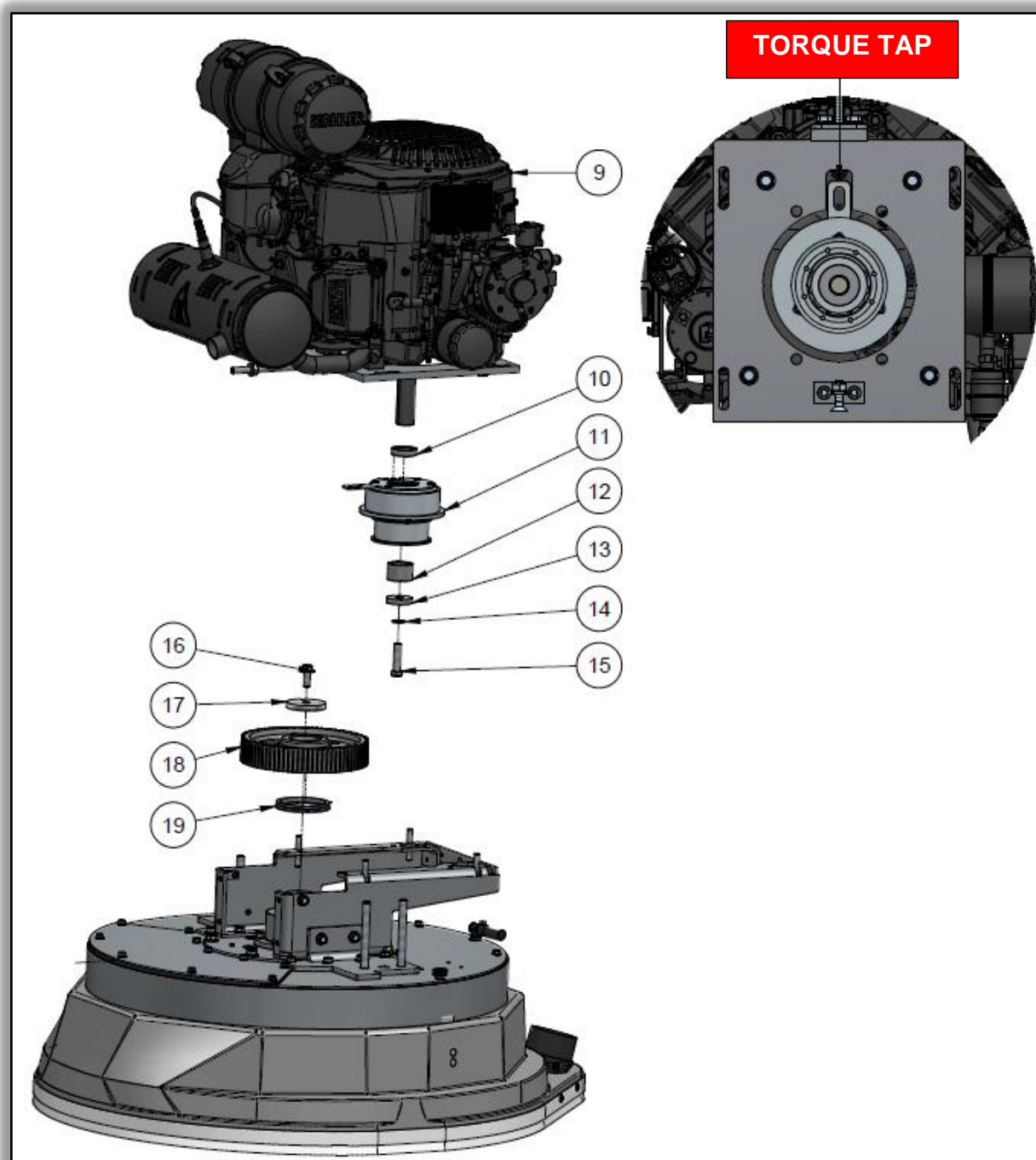

To replace the clutch:

- Dismount the engine assembly by following the steps in “CHANGING THE BELT”.
- Once the engine is dismounted unscrew the bolt (pos. 15). Remove the clutch and its components. Remember the order of the components:
 - Pos. 15 - Bolt;
 - Pos. 14 – Washer;
 - Pos. 13 – Front Washer;
 - Pos. 12 – Sleeve;
 - Pos. 11 – Clutch;
 - Pos. 10 – Clutch washer;

IMPORTANT!!! The engines base plate has a slot. The clutch has a torque tap, which must fit in this slot. Check the figure above.

Note: The above mentioned parts can vary depending on the engine model you are using. For more information check the spare parts.

To replace the central pulley:

- Unscrew the bolt (pos. 16).
- Remove the washer (pos. 17).
- Dismount the central pulley (pos. 18) and replace it.

Note: Always check the condition of the V-ring (pos. 19) and replace if necessary.

9.4. REPLACING THE MAIN TIMING BELT

To replace the main belt, set the machine into “tool change” position. Dismount the tool holders (1) and remove the protective cover (2) (Check point 6.1. PROTECTIVE COVER). Once done follow the steps bellow.

IMPORTANT!!! KEEP THE TORQUE REQUIREMENTS FOR THE ALUMINUM CASTING

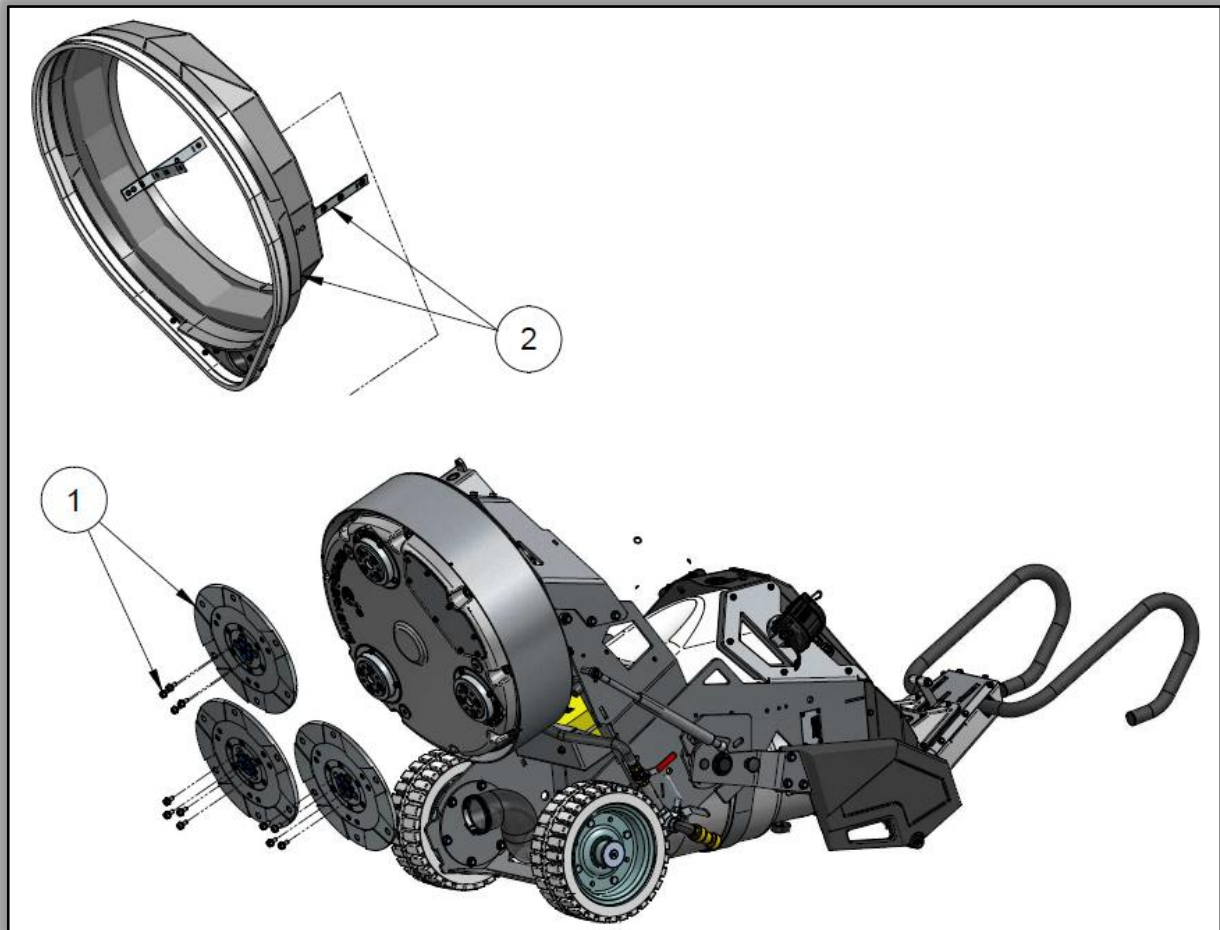

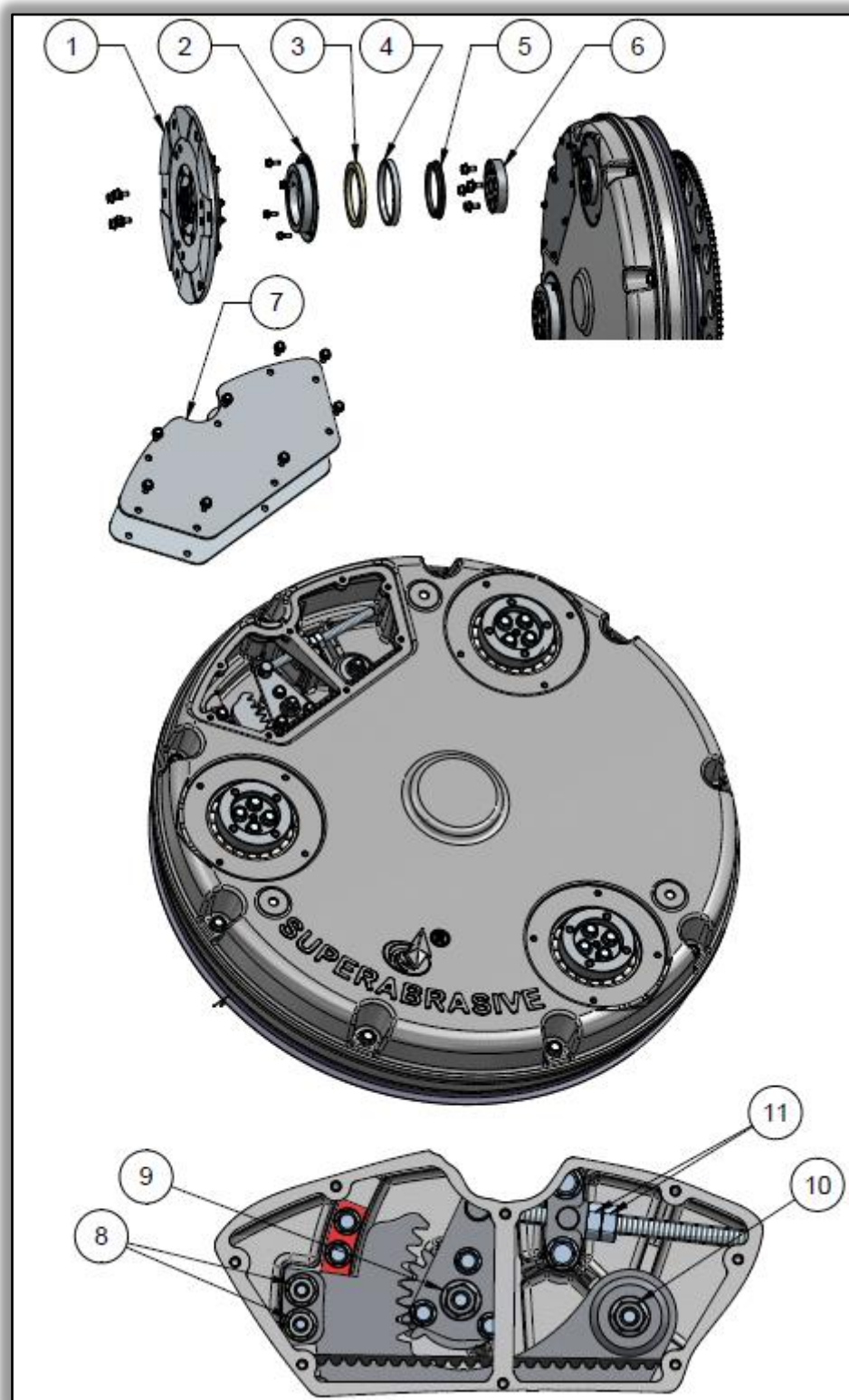

To replace the belt follow the steps:

- Remove the tool holders (1) along with the outer cover (2), the felt ring (3), the ring (4), the seal (5) and the adaptor (6).
- Once all the tool holders are removed, open the service cover (7).
- Before manipulating the tensioner, make sure to loosen the nuts (8), (9) and (10).
- Once the above mentioned nuts are loosen, unscrew the nuts (11) enough to push the tensioner and loosen the belt.

IMPORTANT!!! The belt must be loosened before opening the transmission.

- Once the belt is loosened, unscrew the 9 bolts and dismount the bottom cover (12).

NOTE! Three of the nine bottom cover holes (shown on the images with red arrow) are threaded with M12. Their purpose is to screw 3 bolts M12x30 or longer at the same time in order to separate the bottom cover form the top one and open the grinding head.

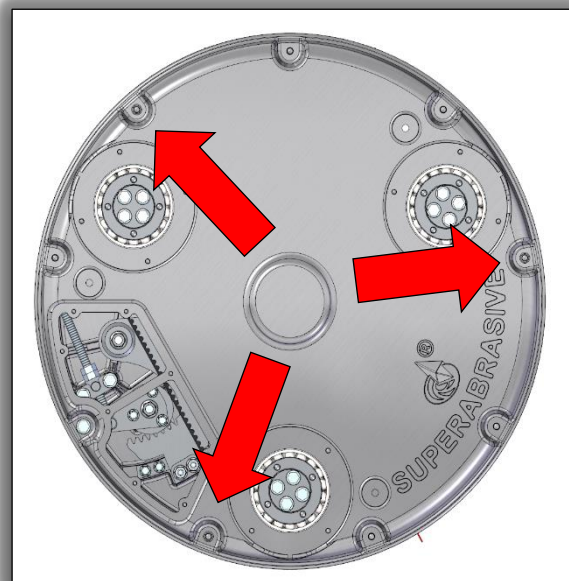
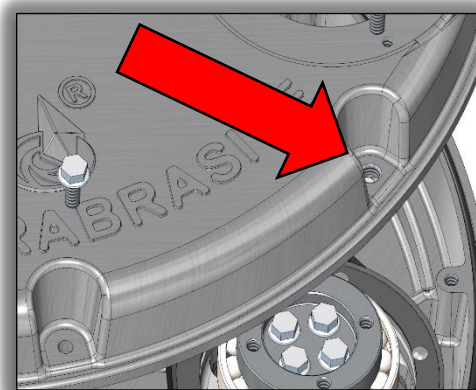
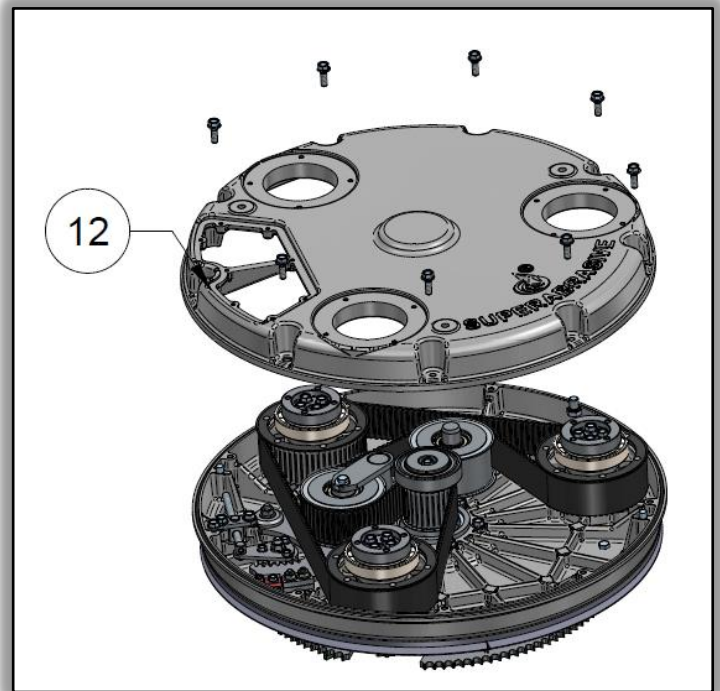

- When the grinding head is opened, the belt is already loosened and it can be dismantled. After the old belt is dismantled:
 - Clean the pulleys and the surrounding area.
 - Check all the bearings of the pulley units and tensioner for excessive clearance or noise.
- Rotating the tensioner will allow the center distance to be reduced so that the timing belt may be fitted without force. **Installation with the use of force is not permissible at any time as this can damage the high quality, low stretch tension cord and other components. This damage is not often visible.**
- Install the belt according to the diagram below, paying close attention to the orientation of the belt relative to every pulley.

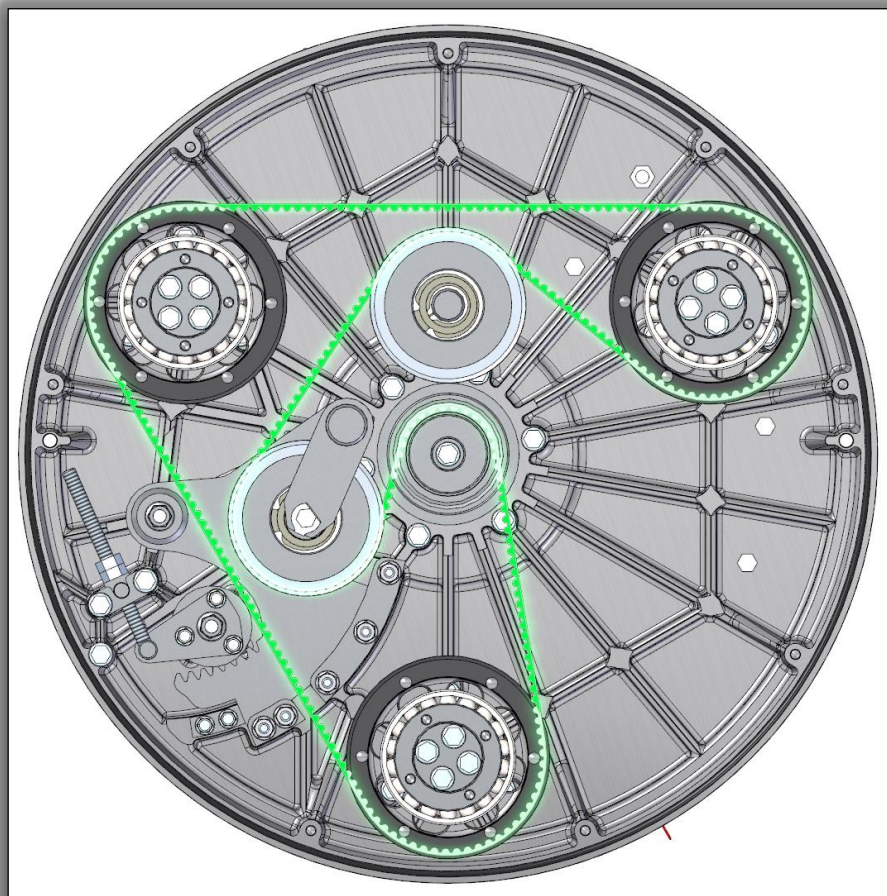

- Once the belt is installed, make sure that the teeth of the belt are properly fitted into the teeth of the pulleys.
- Use the tensioner to slightly tighten the belt. When the belt is slightly tightened, use two of the M8 bolts (you have them from disassembling the toolholders) and screw them into one of the holders. Once done use a screwdriver to turn the holder 3-5 full rotations to make sure the belt is well fitted.

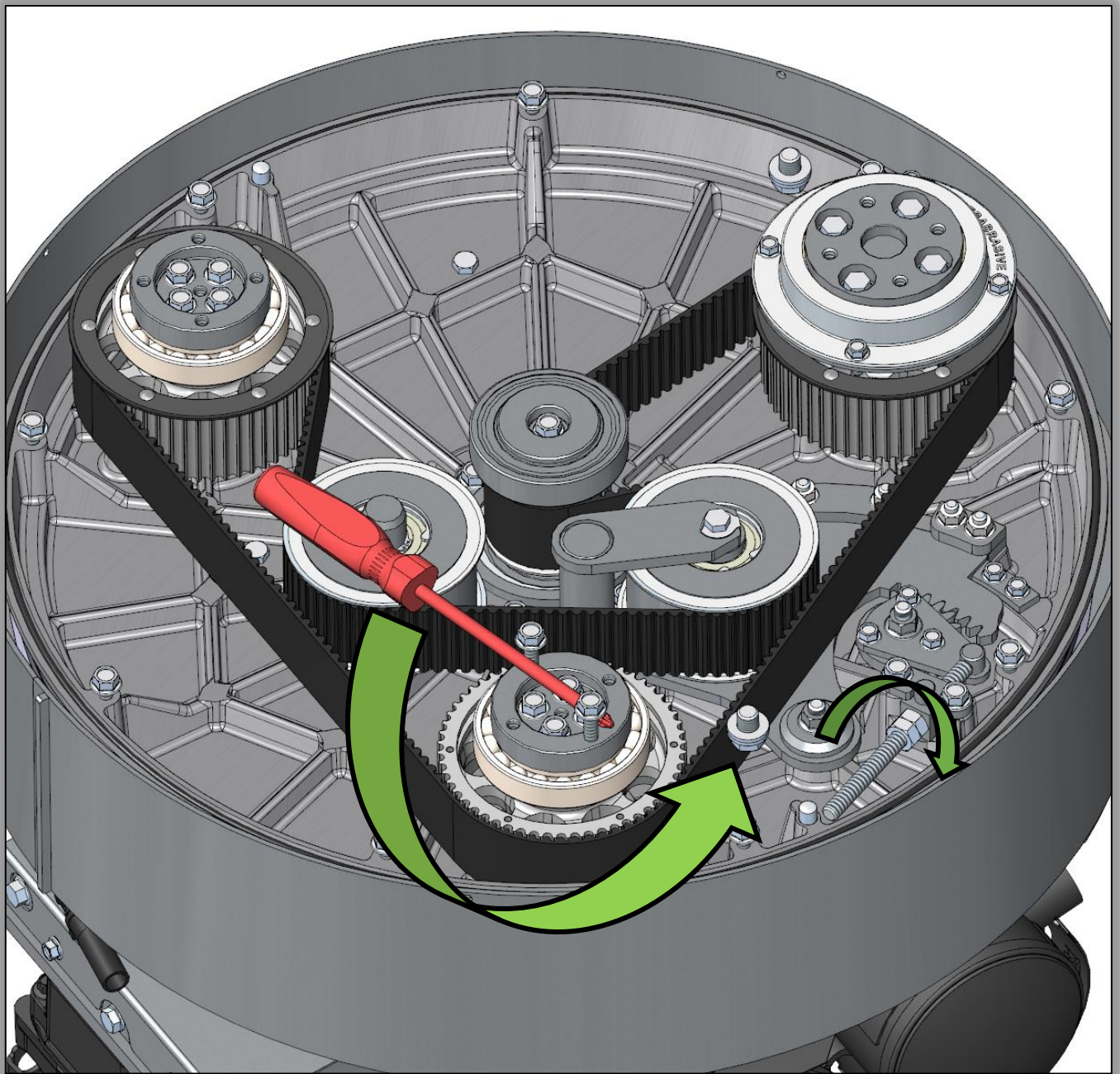

- After the new belt is mounted, reinstall the bottom cover carefully by following the steps in reverse order. **The belt must be loose when mounting the bottom cover!**

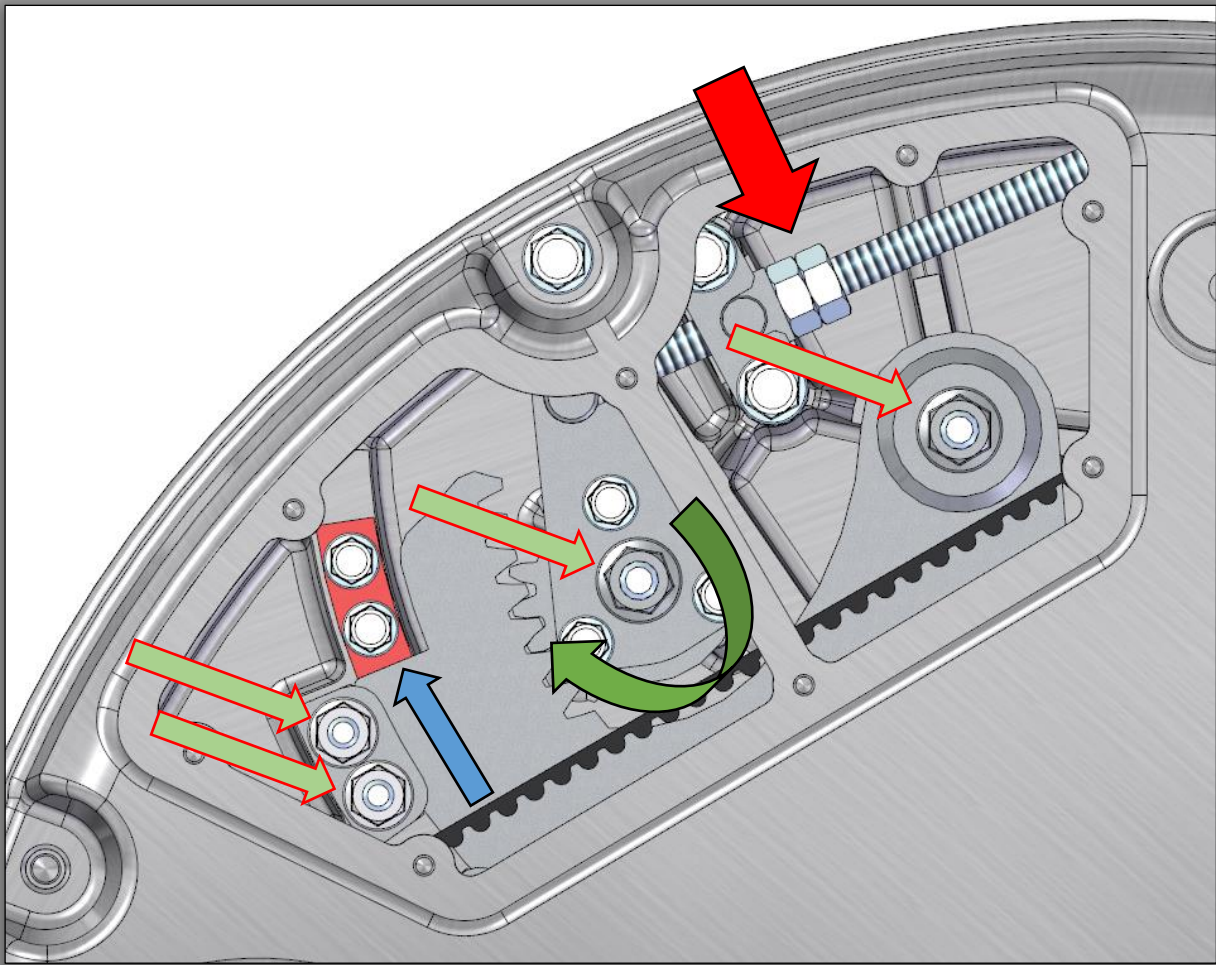

- Once the bottom cover is mounted firmly, tighten the nuts (**red arrow**) in order to tension the new belt. The belt must be tightened until the tensioner plate contacts the thrust plate (**in red**). Once the tensioner plate touches the thrust plate, the new belt is ready. At last retighten the nuts pointed with **green arrows**. Once done, the cover can be closed and the tool holders mounted back.

The belt can be also tensioned by using frequency tension tester (Optibelt 3 TT). Tension must be 105-113 Hz.

IMPORTANT!!! When the main timing belt is replaced, the planetary drive must be synchronized.

IMPORTANT!!! NEVER "OVER" TENSION THE BELT, THE BELT WILL BE DESTROYED AND IT WILL NEVER RECOVER ITS ORIGINAL TENSION

9.4.1. ACCESSING THE PLANETARY DRIVE

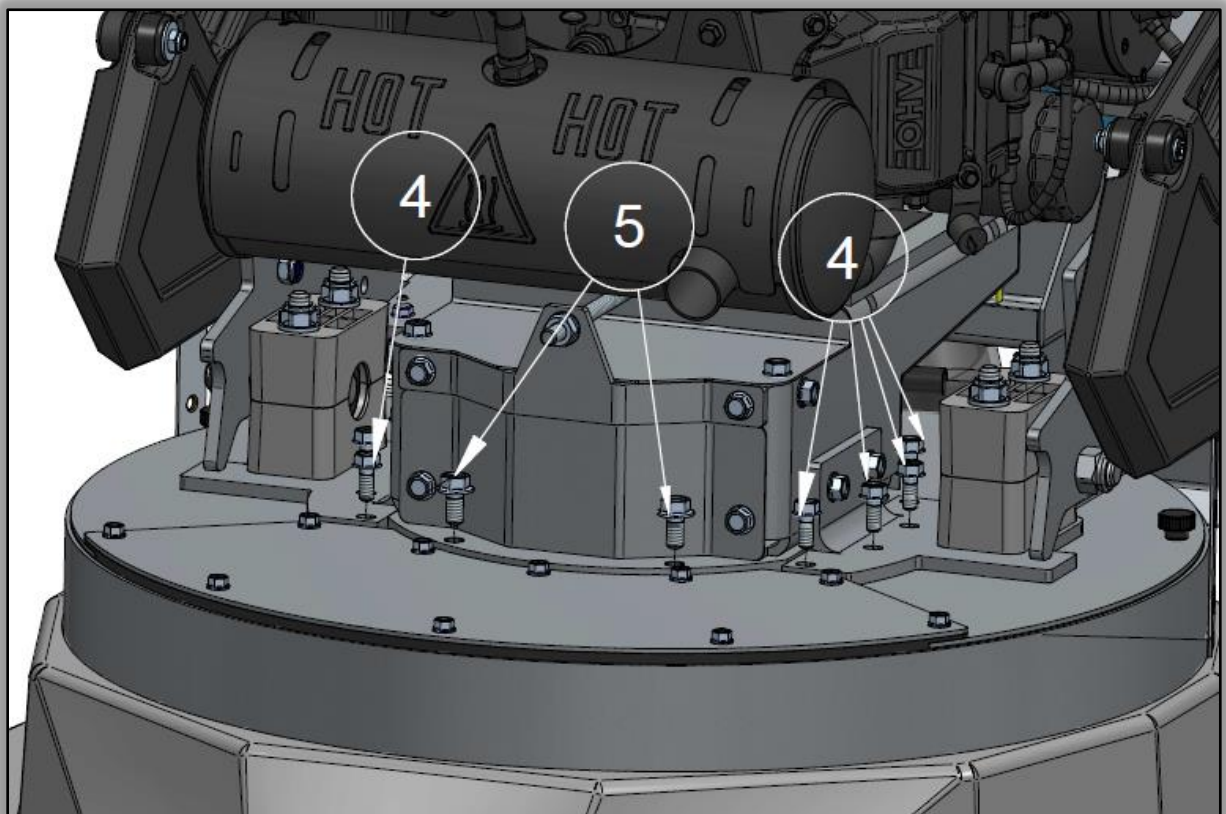
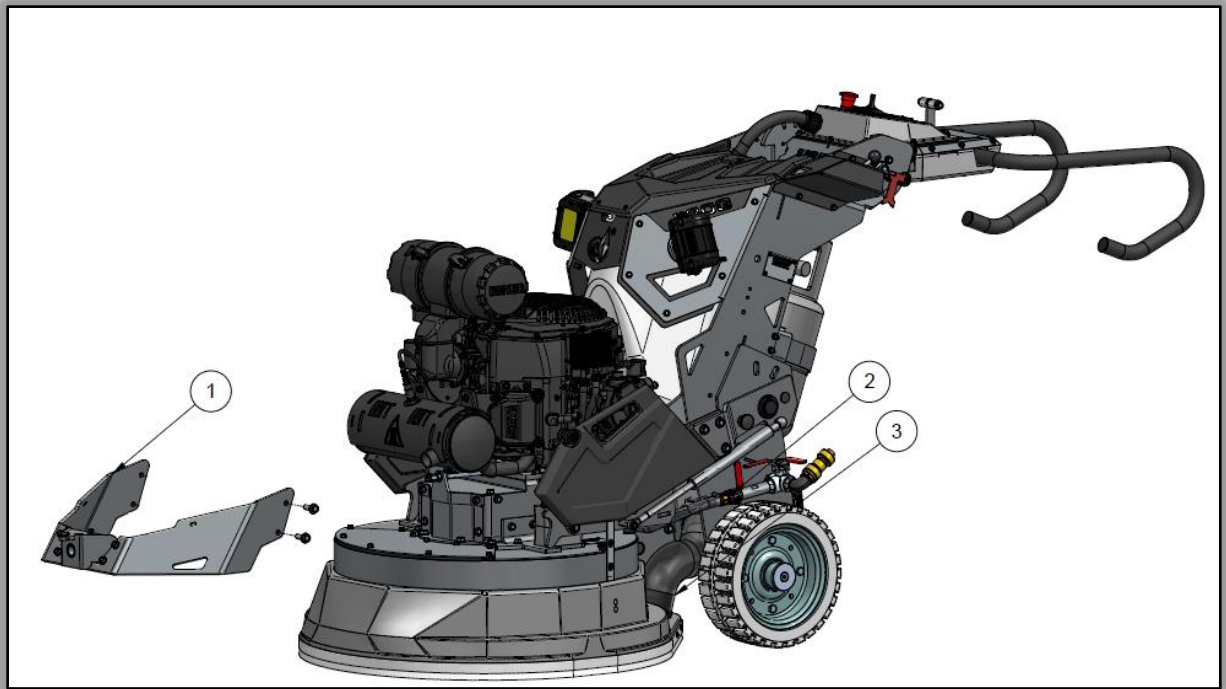

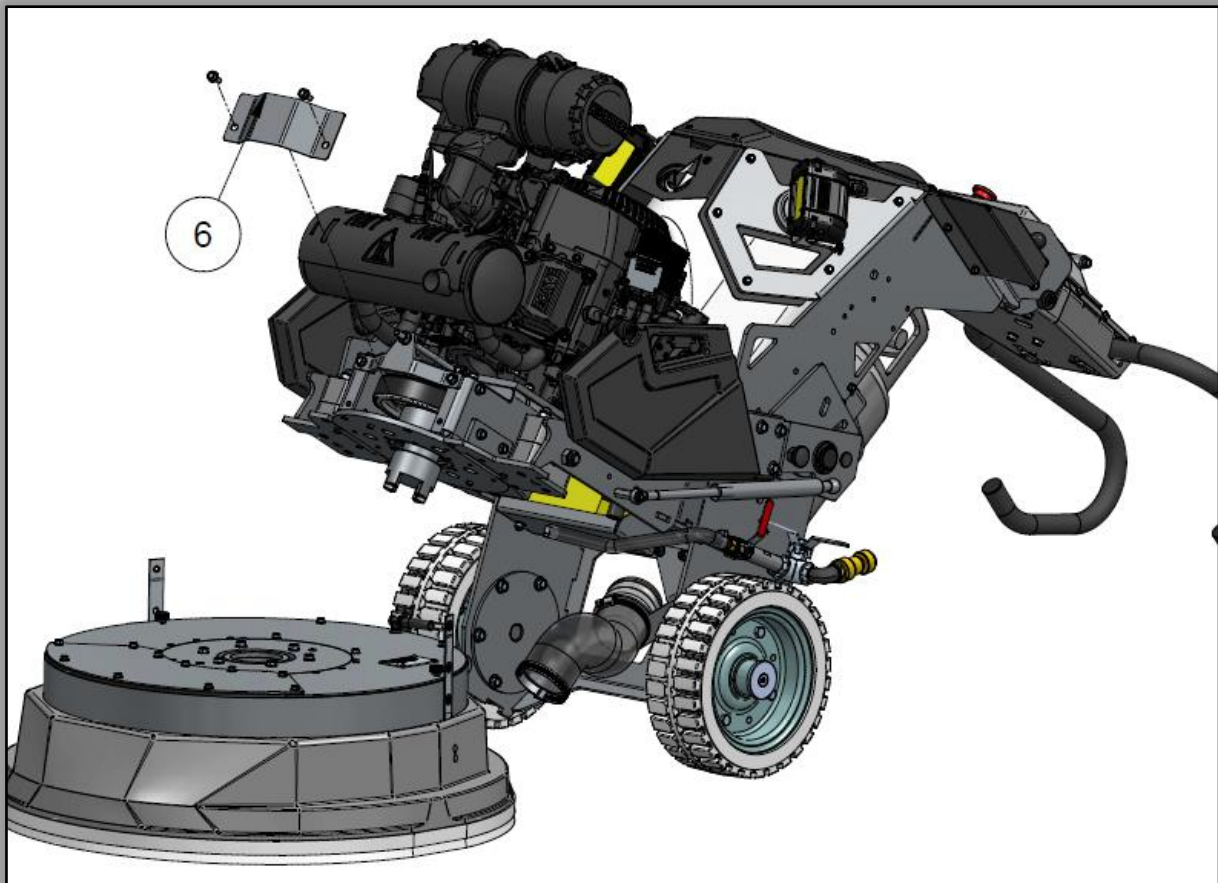

To reach the planetary drive and synchronize it, follow the steps from the figures above:

- Dismount the front bumper (1) and detach the water hose (2) and the dust hose (3).
Note! Detach the water hose (2) directly from the water tap. Access is easier than detaching it from the grinding head.
- Unscrew the bolts (4) and (5).
IMPORTANT!!! Before unscrewing the bolts, make sure the weights are in position 1. (check point 6.3 ADJUSTING THE WEIGHTS).
- Unscrew I remove the protective cover (6).

9.4.2. SINCRONIZING THE PLANETARY DRIVE

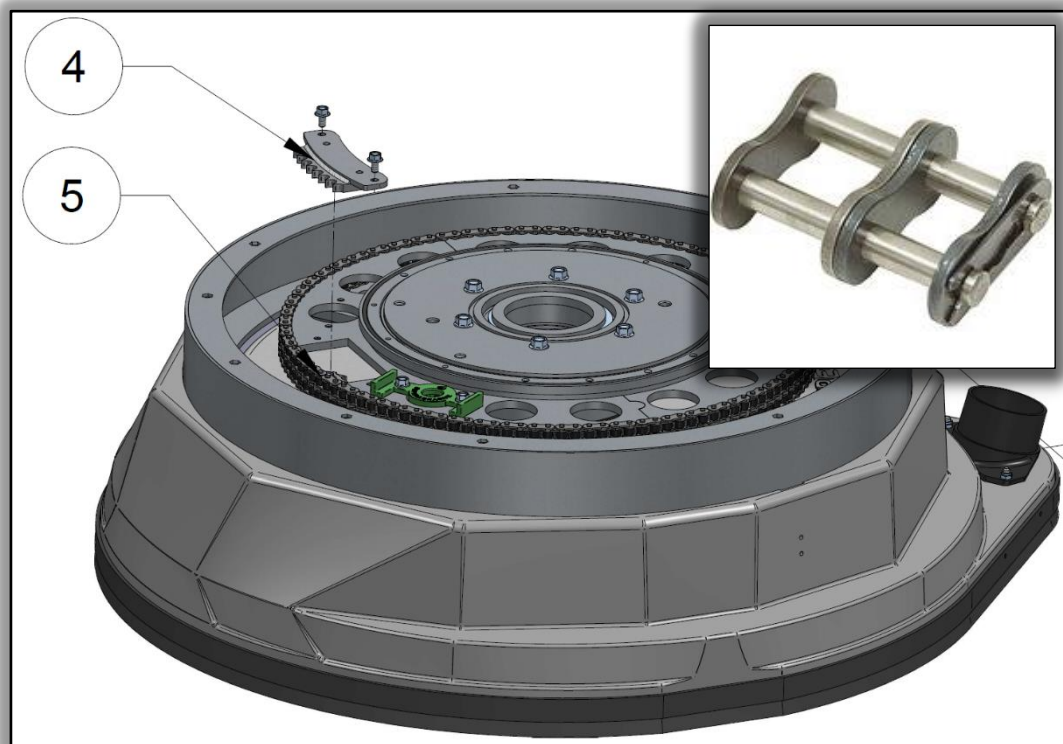
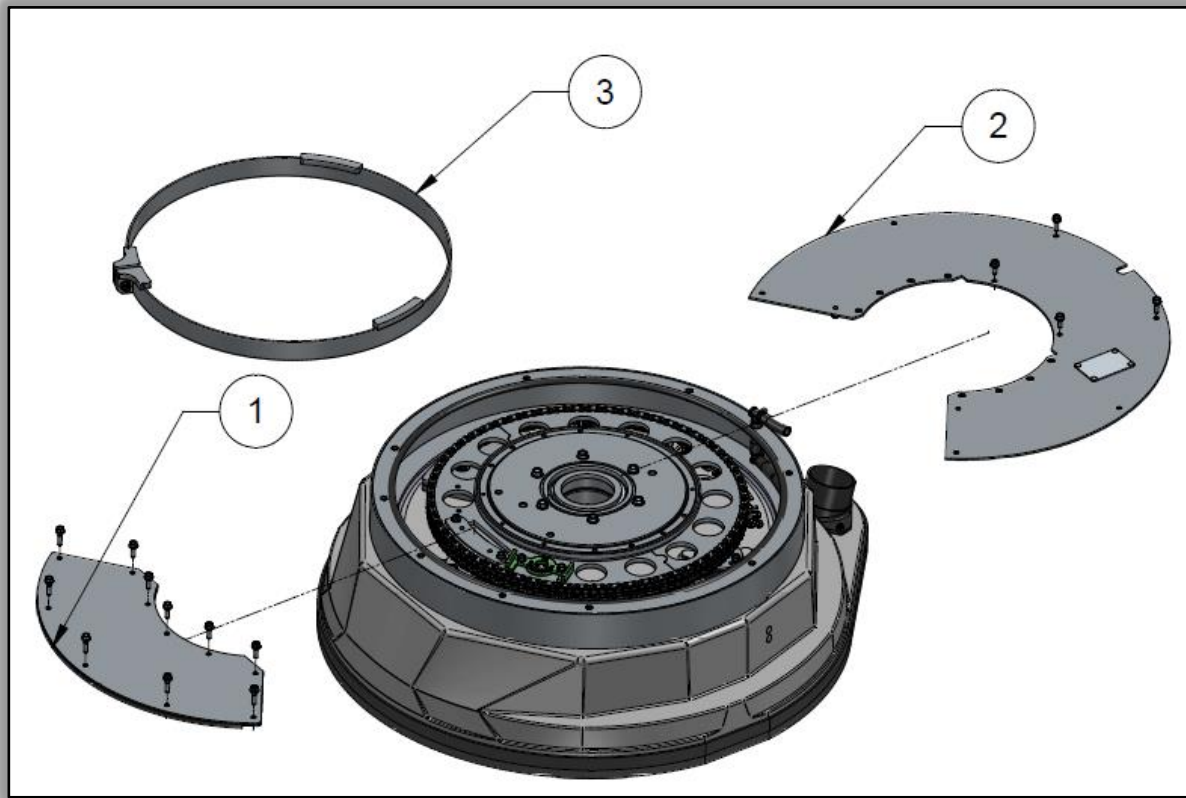

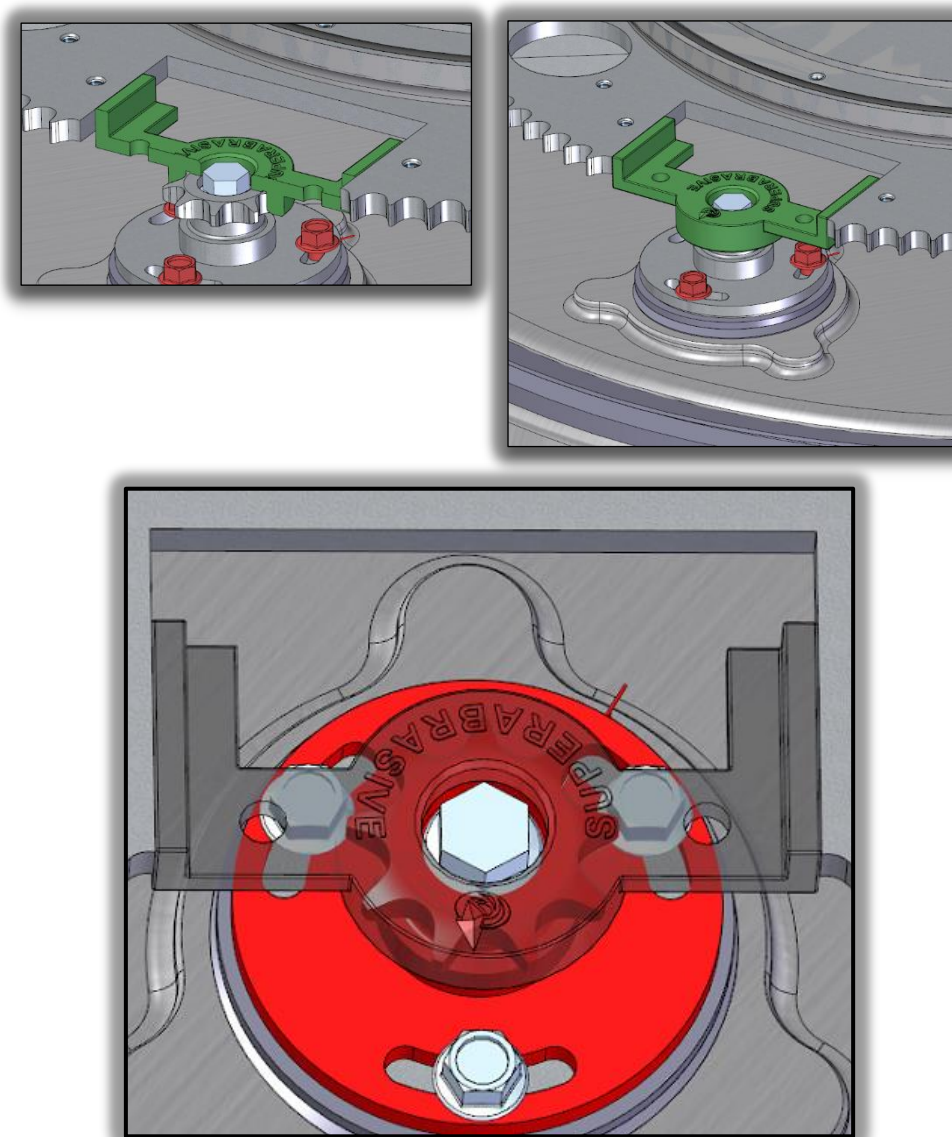

To synchronize the planetary drive:

- Unscrew and remove the covers (1) and (2).
- Unscrew and remove the planetary chain clamp (3).
- Unscrew and remove the service gear unit (4).
- Detach the chain connecting link and remove the chain (5).
- A special tool is mounted on the main chain sprocket. The tool is used to adjust and synchronize the 3 side chain pulleys with the chain.
- Set the tool on top of the side pulley as shown on the images. Once the tool is mounted on the side chain pulley and it is synchronized, tighten the three side bolts (in red) enough to avoid movement when removing the tool. When the tool is removed screw the side bolts firmly and finally tighten the center bolt.
IMPORTANT!!! When synchronizing a side chain pulley with the tool, always follow the order – first tight the three side bolts and then tight the center bolt. If the center bolt is tightened first the pulley will move and it won't be synchronized.

- Make sure to mount the tool back to the main chain sprocket in order to avoid losing it.
- Mount back the chain and the rest of the parts in reversed order.

NOTE!!! If changing some of the side planetary chain pulley or the main planetary chain sprocket need to be replaced, a synchronization is needed.

IMPORTANT!!! When attaching the carriage to the head, rotate the central pulley (7) carefully in order to fit the ROTEX clutch (9).

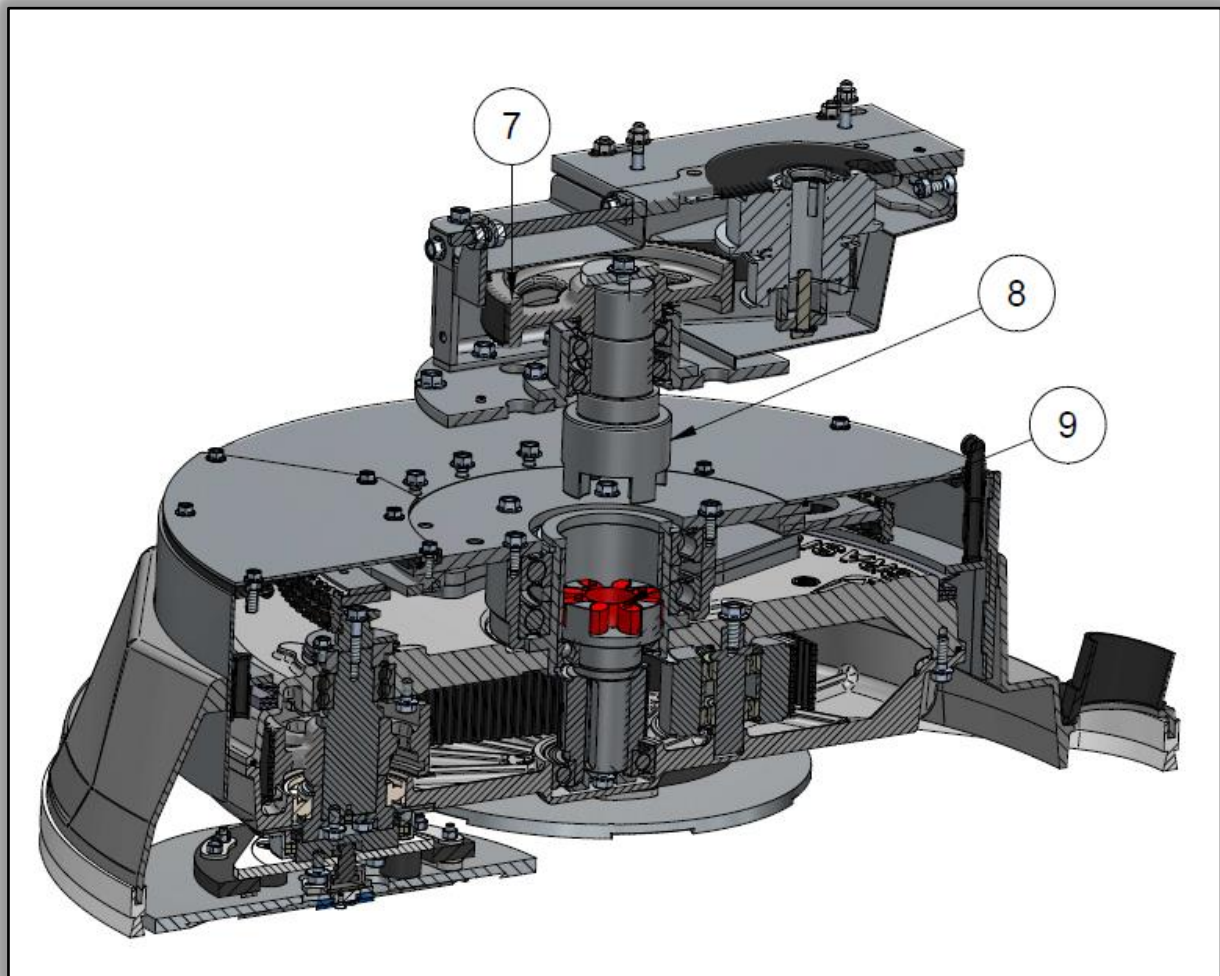

The planetary drive described above is no longer supported from us. If any malfunction occurs, the following kit must be ordered: [A115](#).

The A115 kit replaces the whole planetary drive by adding chain tensioner.

For installing instructions contact your authorized dealer.

9.5. PLANETARY DRIVE WITH CHAIN TENSIONER

1. To replace the planetary chain or the springs follow the steps:
 - Unscrew the nuts, which are holding the springs of the tensioner. Release the springs.
 - Unscrew and remove the rotation limiter. Now the chain can be replaced.
2. To replace the main planetary chain wheel (MPCW):
 - Once the chain is removed, unscrew the bolt, dismount and replace the main planetary chain wheel.
3. To replace the chain wheel of the tensioner:
 - Unscrew and dismount the plate pos. 2.
 - Remove the circlip pos.3.
 - Dismount the chain wheel and mount the new one by following the reversed order of the steps above.

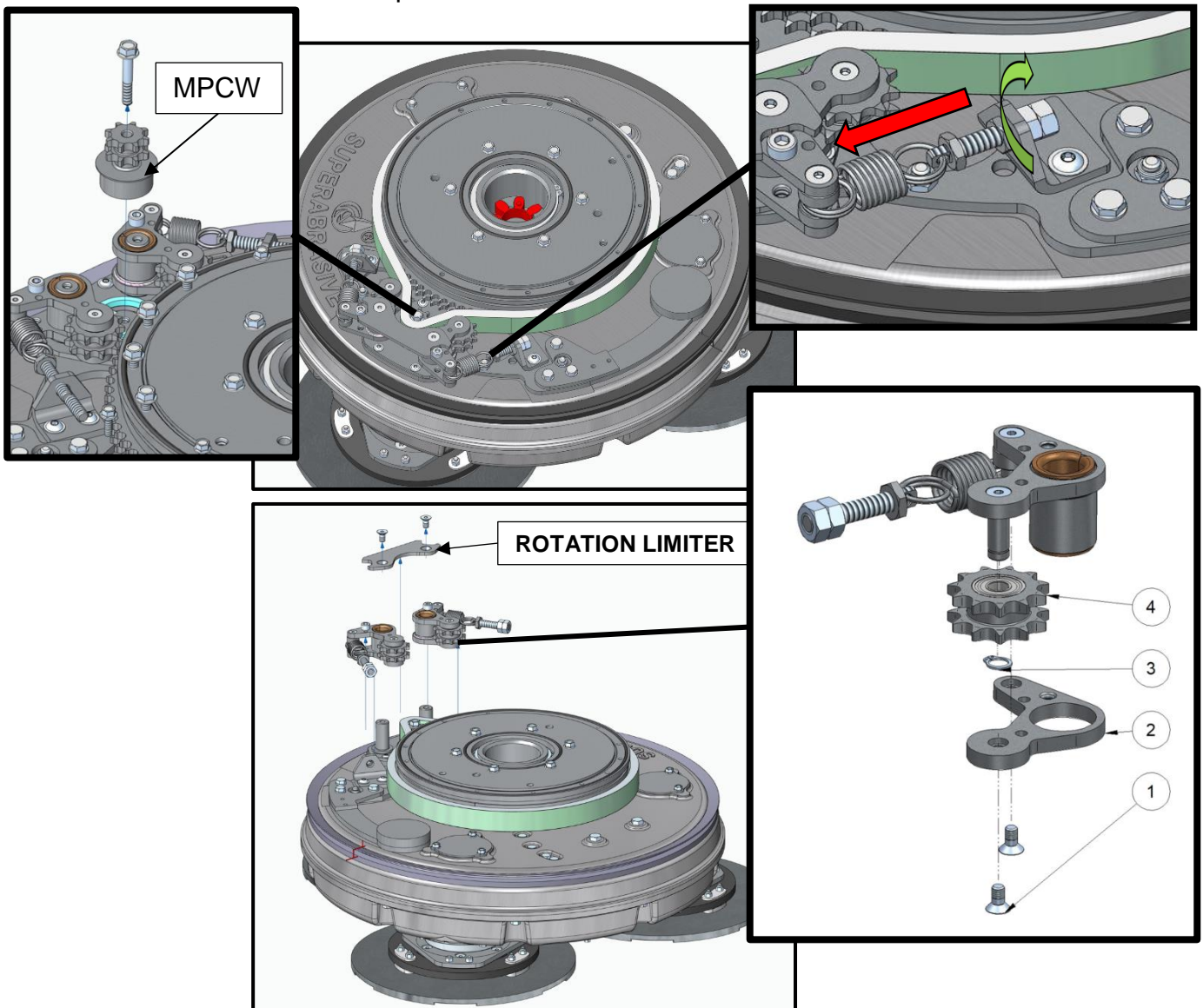

9.5.1. MAINTENANCE

To ensure optimal performance and extend the life of the planetary drive we recomemned cleaning and lubricating the chain every **200 hours**.

Make sure to open the planetary drive by following the steps from above.

IMPORTANT!!! Once the planetary chamber is opened, make sure to lubricate the chain along its entire lenght.

9.6. TOOLHOLDERS

9.6.1. REPLACING V RINGS AND FELT RINGS

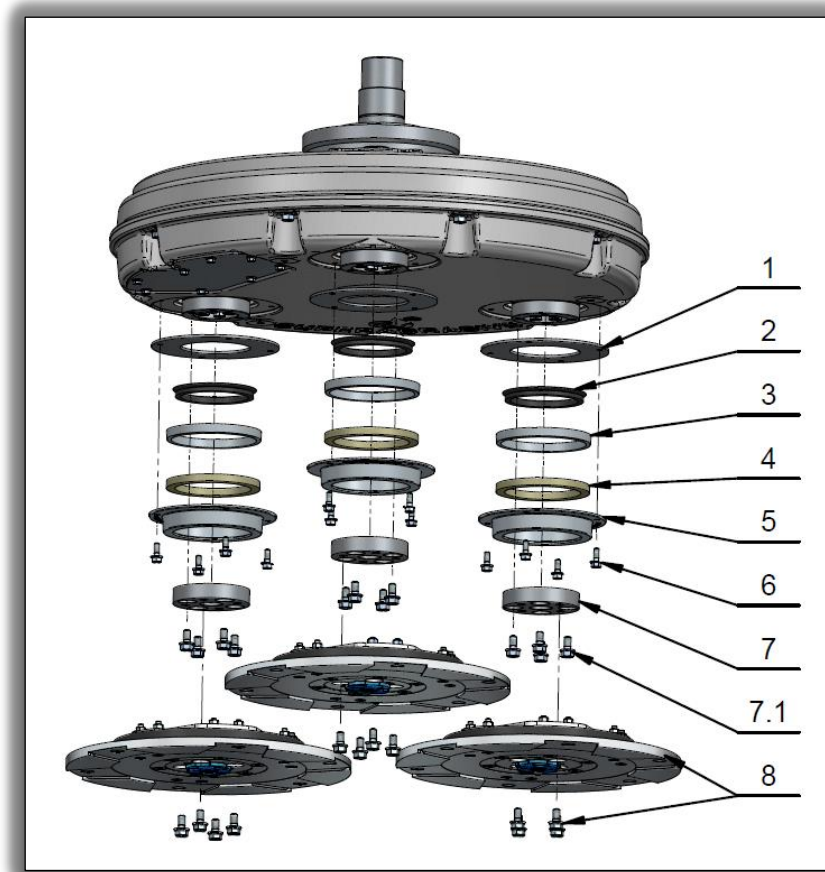

To replace the V-ring and the felt ring follow the steps:

- Unscrew and remove the tool holder (8).
- Unscrew and remove the adaptor (7) and the outer cover (5).
- Replace the V-ring or the felt ring and assemble in reversed order.

NOTE! The flanges pos. 1 are glued with silicone to the grinding head's body.

9.6.2. REPLACING THE BUFFERS AND THE ELASTIC ELEMENT



Figure 9.4.2.1



Figure 9.4.2.2

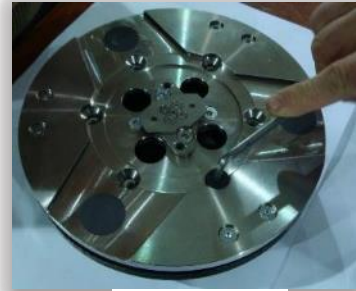

Figure 9.4.2.3



Figure 9.4.2.4



Figure 9.4.2.5



Figure 9.4.2.6



Figure 9.4.2.7



Figure 9.4.2.8



Figure 9.4.2.9



Figure 9.4.2.10



Figure 9.4.2.11

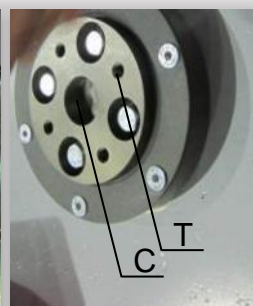

Figure 9.4.2.12

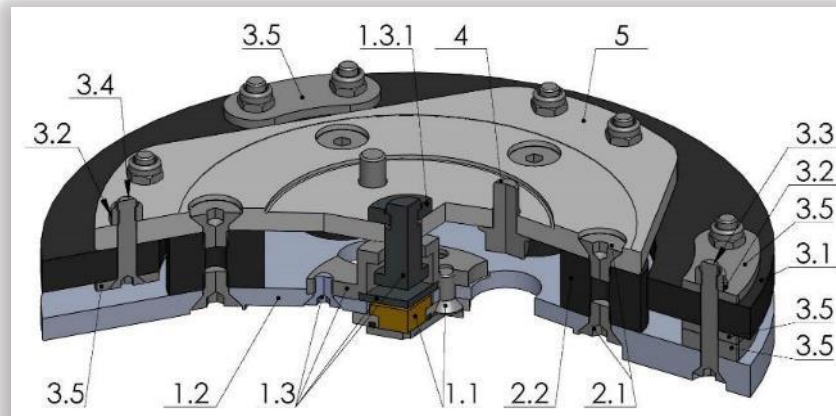

Figure 9.4.2.13

When the TOOL HOLDER is disassembled you can change defective parts – elastic element, buffers, etc.

Lift the locking pin (Fig. 9.4.2.1) to dismount the retaining washer (Fig. 9.4.2.2). Take out the screws on the buffers and the nuts of the elastic element (Fig. 9.4.2.3; Fig. 9.4.2.4). Remove the elastic element from the QC plate (Fig. 9.4.2.5). While the holder is dismantled (Fig. 9.4.2.6; Fig. 9.4.2.7) clean the parts and replace the defective with new ones.

Assemble the holder with new buffers, new screws and new elastic element. Put the retaining washer (Fig. 9.4.2.8) and push the locking pin (Fig. 9.4.2.9). This will prevent the fall of the washer when mounting the holder on the machine.

Make sure the four bolts which are holding the adaptor (Fig. 9.4.2.12) are reliably tighten. Mount the holder on the machine using the same socket as mentioned above (Fig. 9.4.2.10; Fig. 9.4.2.11). The retaining washer fits into the central hole C of adaptor and the four bolts into the thread holes (Fig. 9.4.2.12). The holder is centered on the outside diameter of the adaptor. Ensure the connection of the holder on the forehead of the adaptor and then tight evenly the four bolts. Tightening force of the bolts has to be 22...25N.m(16...18 ft/lbs). Mounting the holder without retaining washer (Fig. 9.4.2.2) is **INADMISSIBLE** because the security system preventing the separation of part of the holder in case of broken buffers and elastic element will not function!

You can change the butterfly of the holder without dismounting the holder of the machine. Fig. 9.4.2.13 is 3-d section view of the holder, showing its parts. The numbering is the same as in Spare parts

9.7. REPLACING THE PULLEY UNITS

To replace the pulley unit unscrew and dismount the bushing bearing set (1) and then dismount the pulley unit (2).

IMPORTANT!!! When replacing a pulley unit, the planetary chain must be dismounted. After a pulley unit is replaced, the planetary side chain pulley which is mounted to the same (changed) pulley unit, must be synchronized by using the tool provided. [SIDE CHAIN PULLEY](#)

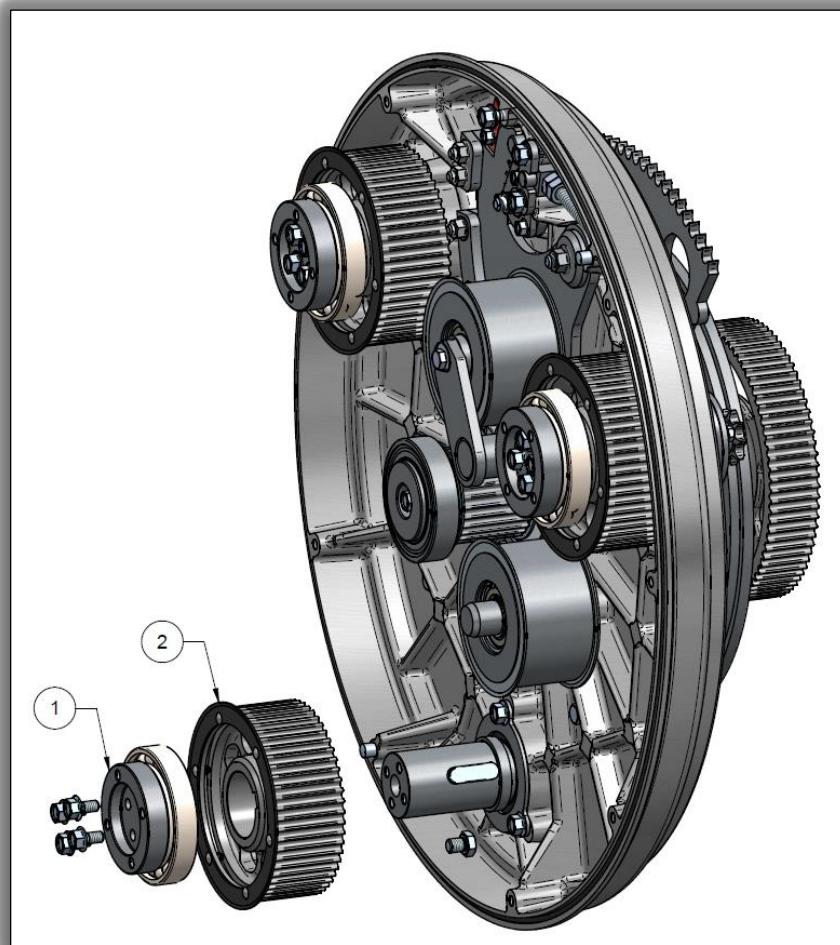

10. BATTERY

10.1. REPLACING/CHARGING THE BATTERY

To replace the battery, the water tank must be dismantled from the carriage. To do so, open the service cover (1). Unscrew the storage department (2) and remove it. Unscrew the latch (3) and detach the tank from the water hose. Remove the tank (4).

Once the tank is removed unscrew and remove the battery plate (5). Disconnect the battery from the harness. Replace the battery with new one and do the steps in reversed order.

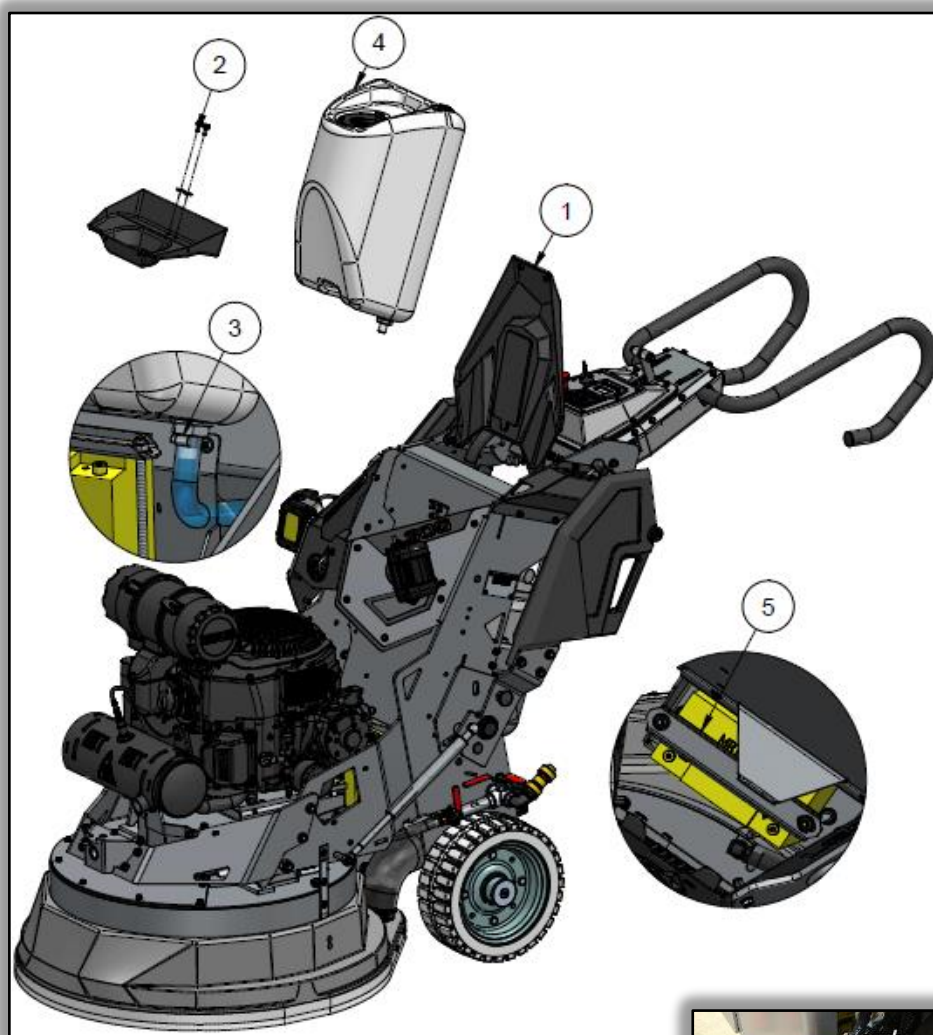

To charge the battery, it can either be accessed and charged by following the previous steps or it can be also charged by using the red connector.



11. EMISSION CONTROL WARRANTY STATEMENT

11.1. CALIFORNIA EMISSION CONTROL WARRANTY STATEMENT YOUR WARRANTY RIGHTS AND OBLIGATIONS

The California Air Resources Board and Superabrasive Inc. are pleased to explain the emissions control system warranty on your 2016 small off-road engine (SORE). In California, new SORE must be designed, built and equipped to meet the State's stringent anti-smog standards. Superabrasive Inc. must warrant the emission control system on your SORE for the period of time listed below provided there has been no abuse, neglect or improper maintenance of your SORE.

Your emission control system may include parts such as the carburetor, fuel-injection system, the ignition system, catalytic converter, fuel tanks, fuel lines, fuel caps, valves, canisters, filters, vapor hoses, clamps, connectors, and other associated emission-related components.

Where a warrantable condition exists, Superabrasive Inc. will repair your SORE at no cost to you including diagnosis, parts and labor.

11.2. MANUFACTURER'S WARRANTY COVERAGE

The emission control system is warranted for 2 years. If any emission-related part on your equipment is defective, the part will be repaired or replaced by Superabrasive Inc.

11.3. OWNER'S WARRANTY RESPONSIBILITIES

As the small off-road engine (SORE) owner, you are responsible for the performance of the required maintenance listed in your owner's manual. Superabrasive Inc. recommends that you retain all receipts covering maintenance of your SORE engine, but Superabrasive Inc. cannot deny warranty solely for the lack of receipts or for your failure to ensure the performance of all scheduled maintenance.

As the SORE owner you should however be aware that Superabrasive Inc. may deny your warranty if your SORE or its part has failed due to abuse, neglect, improper maintenance or unapproved modification.

You are responsible for presenting your utility equipment engine to a Superabrasive Inc. distribution center as soon as the problem exists. The warranty repairs should be completed within a reasonable amount of time, not to exceed 30 days. If you have any questions regarding your warranty rights and responsibilities, you should contact Superabrasive Inc. at 1-(800)-987-8403 or by e-mail at info@superabrasive.us

Superabrasive Inc

9411 Jackson trail Rd

Hoschton, GA

USA, 30548

11.4. GENERAL EMISSIONS WARRANTY COVERAGE

Superabrasive Inc. warrants to the ultimate purchaser and each subsequent purchaser that the equipment is:

Designed, built and equipped so as to conform with all applicable regulations; and

Free from defects in materials and workmanship that cause the failure of a warranted part to be identical in all material respects to that part as described in Superabrasive Inc. application for certification.

The warranty period begins on the date the equipment is delivered to an ultimate purchaser or first placed into service. The warranty period is two years.

Subject to certain conditions and exclusions as stated below, the warranty on emission-related parts is as follows:

(1) Any warranted part that is not scheduled for replacement as required maintenance in the written instructions supplied, is warranted for the warranty period stated above. If the part fails during the period of warranty coverage, the part will be repaired or replaced by Superabrasive Inc. according to subsection (4) below. Any such part repaired or replaced under warranty will be warranted for the remainder of the period.

(2) Any warranted part that is scheduled only for regular inspection in the written instructions supplied is warranted for the warranty period stated above. Any such part repaired or replaced under warranty will be warranted for the remaining warranty period.

(3) Any warranted part that is scheduled for replacement as required maintenance in the written instructions supplied is warranted for the period of time before the first scheduled replacement date for that part. If the part fails before the first scheduled replacement, the part will be repaired or replaced by Superabrasive Inc. according to

subsection (4) below. Any such part repaired or replaced under warranty will be warranted for the remainder of the period prior to the first scheduled replacement point for the part.

(4) Repair or replacement of any warranted part under the warranty provisions herein must be performed at a warranty station at no charge to the owner.

(5) Notwithstanding the provisions herein, warranty services or repairs will be provided at all of our distribution centers that are franchised to service the subject engines or equipment.

(6) The SORE owner will not be charged for diagnostic labor that is directly associated with diagnosis of a defective, emission-related warranted part, provided that such diagnostic work is performed at a warranty station.

(7) Superabrasive Inc. is liable for damages to other engine or equipment components proximately caused by a failure under warranty of any warranted part.

(8) Throughout the SORE warranty period stated above, Superabrasive Inc. will maintain a supply of warranted parts sufficient to meet the expected demand for such parts.

(9) Any replacement part may be used in the performance of any warranty maintenance or repairs and must be provided without charge to the owner. Such use will not reduce the warranty obligations of Superabrasive Inc.

(10) Add-on or modified parts that are not exempted by the Air Resources Board may not be used. The use of any non-exempted add-on or modified parts by the ultimate purchaser will be grounds for disallowing a warranty claims. Superabrasive Inc. will not be liable to warrant failures of warranted parts caused by the use of a non-exempted add-on or modified part.

11.5. WARRANTED PARTS

The repair or replacement of any warranted part otherwise eligible for warranty coverage may be excluded from such warranty coverage if Superabrasive Inc. demonstrates that the SORE has been abused, neglected, or improperly maintained, and that such abuse, neglect, or improper maintenance was the direct cause of the need for repair or replacement of the part. That notwithstanding, any adjustment of a component that has a factory installed, and properly operating, adjustment limiting device is still eligible for warranty coverage. The following emission warranty parts are covered:

(1) Catalytic converter

(2) Fuel system: Carburetor, pressure regulator and fuel lock off

(3) Ignition system

(4) Intake system including pre-filter

(5) Exhaust manifold