

U.S.SAWS™

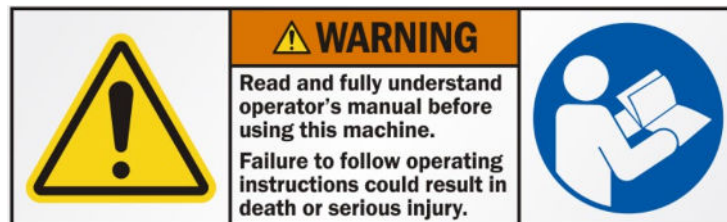

U.S.SAWS MARK III OPERATING MANUAL



Notice of Copyright Protection

Copyright 2020, by U.S.SAWS . All rights reserved. This work may not be reproduced or disseminated in whole or in part by any means without the prior written permission of U.S.SAWS

04-26-2022

U.S.SAWS™

**SURFACE PREP
DIVISION**

P: 877-817- 6687 F: 813-621-7125
Visit us at www.ussaws.com
sales@ussaws.com



INTRODUCTION & SPECIFICATIONS

1.0 INSTRUCTIONS FOR USE OF MANUAL SECTIONS

Section	Page
Table of Contents & Introduction	2
Symbols & Decals	3
Safety Instruction	4 - 5
Pre-Operation Checklist	6 - 8
Operation & Parts	9 - 10
Parts Breakdown	11 - 15
Related Products	16
Warranty & Service	17 - 18



Foreword/Introduction

The owner's manual is intended to point out some of the basic safety situations that may be encountered during the normal operation & maintenance of the U.S.SAWS MARK- III Machine & to instruct you in safety practices for dealing with these conditions. Keep all manuals provided with your machine in a safe place at all times.

The information and specifications included in this publication were in effect at the time of approval for printing. U.S.SAWS reserves the right, however, to discontinue or change specifications or design at any time without notice and without incurring any obligation.

The U.S.SAWS Mark-III is a high performance, high precision saw designed to clean out control joints, remove old joint filler, and make straight accurate cuts in concrete up to 2" deep.

Typical applications for the U.S.SAWS MARK III are to clean out control joints, remove old joint filler, and make straight accurate cuts in concrete up to 2" deep. A specially designed blade guard allows the operator to see the blade yet still covers 98% of it for excellent dust control and a high degree of accuracy. Blade depth is fully adjustable and has a depth lock to prevent over cutting. The concrete cleanout saw fully complies with ANSI diamond blade speed regulations.

	<p>WARNING</p> <p>Read and fully understand operator's manual before using this machine.</p> <p>Failure to follow operating instructions could result in death or serious injury.</p>	
--	--	---

Read this entire operations and maintenance manual before using your new tool. Pay close attention to the Rules for safer operation,

Dangers, Warnings and Cautions.

The purpose of safety symbols and explanations are to attract your attention to possible hazards and how to avoid them. The safety symbols and explanations do not by themselves eliminate any danger. The instructions or warnings they give are not substitutes for proper accident prevention measures.



DANGER: Indicates an imminently hazardous situation that if not avoided, will result in death or serious injury. This signal word is limited to the most extreme situations.



WARNING: Indicates a potentially hazardous situation that, if not avoided, could result in death or serious injury.



CAUTION: Indicates a potentially hazardous situation that, if not avoided may result in minor or moderate injury. It may also be used to alert against unsafe practices that may cause property damage.

2.0 SPECIFICATIONS

Model	Mark-III Dust Buggy
Part Number	SX13700
Grinder Make/ Model	Metabo W24-230
Output Power	15 Amp Electric
Max RPM	6,600
Power Requirements	115V, 60Hz
Max Cutting Depth	2"
Blade Diameter	7" or 8" Dry Diamond
Blade Width	.090", .125", .250"
Blade Arbor	7/8"
Weight	56 lb

Production rates vary but a good operator can easily clean out 10,000 linear feet of new, unfilled joints in an 8-hour shift.
MADE IN USA 25 Year Warranty on Chassis



SYMBOLS & DECALS

3.0 SYMBOLS & DECALS

For Safe Operation

You must be qualified for safe operation of the U.S.SAWS MARK III walk behind machine. You must clearly understand the written instructions supplied by U.S.SAWS, be trained - including actual operation - & know the safety rules & regulations for the job site. It is a safety practice to point out & explain safety signs & practices to others & to make sure they understand the importance of following these instructions.

Be Safe

Human error is the result of many factors: carelessness, fatigue, sensory overload, preoccupation, unfamiliarity with the machine or attachments, or drugs or alcohol, to name a few. You can avoid serious injury or death caused by these & other unsafe work practices. Be safe and never assume accidents cannot happen to you.

For your safety and the safety of others, act safely and encourage your fellow workers to act safely as well.



Read and understand operator's manual before using this machine. Failure to follow operating Instructions could result in injury or damage to equipment.



Use only diamond blades (steel centered diamond cutting-off wheels) with this machine. RPM rating on blade must exceed machine max rpm rating. The use of any other blade could result in death or serious injury.

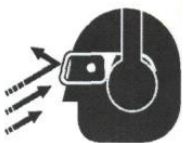

Flying debris and loud noise hazards. Wear ear and eye protection



Exhaust contains poisonous carbon monoxide gas. Breathing it could cause death. Operate machine in well ventilated area.



AVOID INJURY.
Do NOT operate with guard removed. Replace guard before operating machine.



Wear safety boots when operating this machine



Wear appropriate clothing



Wear Head Protection, breathing protection, and the use of hearing protection is mandatory



Wear hand protection



Wear proper electrostatic grounding equipment at all times. Static discharge during fueling can cause explosion



Keep all guards in place



Rotating blade hazard. Do NOT operate with guard up. Keep hands and feet away.



TO AVOID INJURY.
Always inspect saw blades before use. Replace all cracked or damaged blades.



SAFETY INSTRUCTIONS

4.0 SAFETY INSTRUCTIONS

4.1 KNOW THE RULES & YOUR EQUIPMENT.

Most job sites have rules governing equipment use & maintenance. Before starting at a new work location, check with the supervisor or safety coordinator. Ask about any rules or regulations you need to abide.

OSHA enforces federal laws within the United States that apply to the safe operation, application, & maintenance of equipment on job sites. It is the employer's responsibility to comply with these laws.

Do not operate this machine unless you have read the operations and maintenance manual carefully.

4.2 RECEIVE PROPER TRAINING.

Do not operate this machine unless you have received operational and maintenance training from a U.S.SAWS representative or from an authorized distributor for U.S.SAWS.

4.3 PROTECT YOUR FEET.

Observe all applicable local, state and federal safety regulations. Wear OSHA approved foot protection.

4.4 PROTECT YOUR EYES.

Observe all applicable local, state and federal safety regulations. Wear OSHA approved safety glasses.

4.5 PROTECT YOUR LUNGS.

Breathable silica may be generated by use of this product. Silica can cause severe and permanent lung damage, cancer, and other serious diseases. Do not breathe the dust. Do not rely on your sight or smell to determine if the dust is in the air. Silica may be in the air without a visible dust cloud. If air monitoring equipment for silica is not provided by your employer at your work site, you **MUST** wear appropriate respiratory protection when using or servicing the machine. Consult your employer and OSHA regarding the appropriate respiratory protection.

4.6 PROTECT YOUR HEARING.

Observe all applicable local, state and federal safety regulations. Wear OSHA approved hearing protection.

4.7 DRESS PROPERLY.

Do not wear loose clothing or jewelry that can be caught in moving parts. Wear protective hair covering to contain long hair. Keep hair away from motor air vent. Rubber gloves and non-skid footwear are recommended when working outdoors.

4.8 AVOID A DANGEROUS ENVIRONMENT.

Do not expose machine to rain. Do not use machine in wet conditions. Water entering a power tool will increase the risk of electric shock. Keep work area well lit. When working at an elevated location, pay attention to articles and persons below. If operating the power tool in damp locations is unavoidable, use a Ground Fault Circuit Interrupter (GFCI) protected supply. Use of an GFCI reduce the risk of electric shock.

4.9 ELECTRICAL SAFETY

Power tool plugs must match the outlet. Never modify the plug in any way. Do not use any adapter plugs with earthed (grounded) power tools. Unmodified plugs and matching outlets will reduce risk of electric shock. Avoid body contact with earthed or grounded surfaces such as pipes, radiators, ranges and refrigerators. There is an increased risk of electric shock if your body is earthed or grounded.

4.10 ELECTRICAL CORD MANAGEMENT

Do not abuse the cord. Never use the cord for carrying, pulling or unplugging the power tool. Keep cord away from heat, oil, sharp edges or moving parts. Damaged or entangled cords increase the risk of electric shock. When operating a power tool outdoors, use an extension cord suitable for outdoor use. Use of a cord suitable for outdoor use reduces the risk of electric shock.

4.11 AVOID ANY AREAS OR ACTIONS THAT EXPOSE YOU TO CARBON MONOXIDE.

Do not operate in areas where exhaust fumes could accumulate without wearing appropriate respiratory protection. Consult your employer and OSHA regarding use of appropriate respirator for dangerous carbon monoxide gases.

4.12 KEEP WORK AREA CLEAN. DO NOT RUN OVER ANYTHING.

Loose objects could be thrown from crack. Make sure area to be cut is clear from people and any loose objects, nuts, bolts, etc. Never run over any loose objects.

4.13 KEEP CHILDREN AND VISITORS AWAY.

Do not allow anyone to stand in line with the blade path. Do not let children or visitors contact machine or extension cord. Keep children and visitors away from the work area.

4.14 KEEP FIRM GRIP ON MACHINE.

During normal operation as instructed in Section 6.0, keep a firm hold on the handle grips and maintain control of the machine until the blade completely stops.

4.15 SHUT OFF MACHINE.

When not in use, before servicing and when changing accessories shut off motor. Release the lever switch and move the on/off switch to the OFF position. Move the fuel valve lever to the OFF position.

4.16 STORE IDLE EQUIPMENT.

The machine and tools should be stored in a dry and secure location when not in use. Keep equipment out of reach of children.

4.17 OBTAIN SAFETY DATA SHEET (SDS) FOR ALL WORK SURFACE MATERIALS.

This includes primers, all coatings, adhesives, tile and crack filling materials, etc. Do not attempt to cut, clean out or remove material without SDS information. Consult SDS sheet for hazards information. Be aware that some materials are explosive as a dust.



SAFETY INSTRUCTIONS

4.18 DO NOT OVERREACH.

Keep proper footing and balance at all times.

4.19 MAINTAIN MACHINE WITH CARE.

Keep machine clean and follow maintenance procedures for better and safer performance. Keep handles dry, clean, and free from oil and grease. Follow instructions for lubricating and changing accessories.

4.20 REMOVE ADJUSTING TOOLS.

Form a habit of checking to see that tools such as adjusting wrenches are removed from the machine and properly stored before starting the motor.

4.21 STAY ALERT.

Watch what you are doing. Use common sense. Do not operate machine when you are tired or fatigued.

4.22 DO NOT USE DRUGS, ALCOHOL, MEDICATION.

Do not operate machine while under the influence of drugs, alcohol, or any medication.

4.23 KEEP THE RIGHT PARTS IN THE RIGHT POSITIONS.

Do not operate machine with parts missing or improperly mounted.

4.24 CHECK DAMAGED PARTS.

Verify all parts are in good condition and will function properly before using the machine. Check for alignment of moving parts, binding of moving parts, breakage of parts, mounting, and any other conditions that may affect machine operation. Do not operate machine if lever or motor on/off switch does not function properly.

4.25 SECURELY MOUNT ACCESSORIES TO THE MACHINE.

Extra care must be taken at an elevated location to prevent injury to someone on a lower level in the event the tool or accessory should drop. Do not operate without fall protection for operator and debris protection for public.

4.26 NEVER TOUCH THE MOVING PARTS.

Never touch moving parts such as blades, belts and others.

4.27 STOP OPERATION IMMEDIATELY IF ANY ABNORMALITY IS DETECTED.

Stop using machine immediately if any abnormalities are observed during operation. Examples of abnormalities include unusual noise and vibration.

4.28 WHEN REPLACING A PART, USE THE SAME TYPE AND QUALITY.

When replacing a component part with a new one, use only the same type and quality of new part. Never attempt to repair a machine if you are unfamiliar with proper procedures and techniques required.

4.29 LOAD AND UNLOAD SAFELY.

Use proper heavy lifting procedures. Read & understand manuals before loading & unloading.

4.30 SAVE THESE INSTRUCTIONS.

Refer to this operations and maintenance manual as well as any additional instructions included from other manufacturers and organizations such as the Masonry and Concrete Saw Manufacturers Institute®. Never permit anyone to operate the machine without proper instructions.



DUST WARNING

Cutting, especially when DRY cutting, generates dust that comes from the material being cut, which frequently contains silica.

Silica is a basic component of sand, quartz, brick clay, granite and numerous other minerals and rocks. Exposure to excessive amount of such dust can cause:

- Respiratory diseases (affecting your ability to breath), including chronic bronchitis, silicosis and pulmonary fibrosis from exposure to silica. These diseases may be fatal;
 - Skin irritation and rash; and
 - Cancer according to NTP* and IARC*
- * National Toxicology Program, International Agency for Research on Cancer

Take precautionary steps

- Avoid inhalation of and skin contact with dust, mist and fumes;
- Wet cut when feasible, to minimize dust;
- Wear and ensure that all bystanders wear appropriate respiratory protection such as dust masks designed to filter out microscopic particles. (See OSHA 29 CFR Part 1910.1200)

California Prop 65 Warning: Use of this product can cause exposure to materials known to the State of California to cause cancer and/or birth defects or other reproductive harm.



PRE-OPERATION CHECKLIST

5.0 PRE-OPERATION CHECKLIST



Read and understand operator's manual before using this machine. Failure to follow operating instructions could result in injury or damage to equipment.

Figure 1 - Warning label - read and understand manual

5.1 Start by reading the entire Owner's Manual, Rx for Diamond Blade Safety, and Rx for Concrete Saws by the Masonry and Concrete Saw Manufacturers Institute. Then, read the entire MARK-III operations and maintenance manual. Get familiar with the machine's parts. See Figure 1 through Figure 32.



TO PREVENT SERIOUS INJURY DO NOT OPERATE SAW WITHOUT PROPER TRAINING AND UNDERSTANDING OF THE OWNERS MANUAL WHEN OPERATING THIS MACHINE



Keep all guards in place



Wear Head Protection, breathing protection, and the use of hearing protection is mandatory

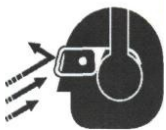

Flying debris and loud noise hazards. Wear ear and eye protection



Wear hand protection



WARNING: Improperly maintaining the Mark III failing to correct a problem before operation could cause a malfunction resulting in a serious injury. Always perform a pre-operation inspection before each operation and correct any problem.

5.2 Observe the condition of your work environment. Walk over area work area and look for hazards. Make sure the work environment is safe and meets all safe-working conditions discussed in section 4, Rules for safer operation.

5.3 Obtain SAFETY DATA SHEET (SDS) for all work surface materials. This includes primers, all coatings, adhesives, tile and crack filling materials, etc. Do not attempt to cut, clean out, or remove material without SDS information. Consult SDS sheet for health hazards information.



WARNING: The U.S.SAWS MARK-III maximum blade operating speed is 6600 rpm. Do not use a blade that is not a dry cut diamond blade. Using a non dry cut diamond blade or a blade rated below 6600 rpm could result in severe blade failure, personal injury or death. See Figure 8 and Figure 9. Never cut material for which the blade was not designed. Check blade manufacturer's guidelines on material to be cut. Never operate a blade in the wrong rotation direction. Verify blade direction when changing blades. The U.S.SAWS MARK-III is designed to cut in a straight line. Never attempt to cut any pattern or follow any joint that is not a straight line.

6600 MAX. RPM

Figure 8 - Max rpm label - maximum blade speed

5.4 Choose the proper dry cut diamond blade for the application, speed and material to be cut. See Figure 9.



Use only diamond blades (steel centered diamond cutting-off wheels) with this machine. RPM rating on blade must exceed machine max rpm rating. The use of any other blade could result in death or serious injury.

Figure 2 - Warning label - use only diamond blades

5.5 Clearly mark all intended cut areas with straight paint or chalk lines.



CAUTION: Running the MARK III generates heat in the motor, blade. Do not touch these components without wearing proper heat protecting work gloves.



PRE-OPERATION CHECKLIST

5.6 Ensure the outer blade guard is installed flush to the main housing and all blade guard mounting screws are in place and secure.

This relates to the warning in 5.7



TO AVOID INJURY.

Always inspect saw blades before use. Replace all cracked or damaged blades.

Figure 3 - Warning label - inspect blades before use



Figure 4 - Pointer wheel

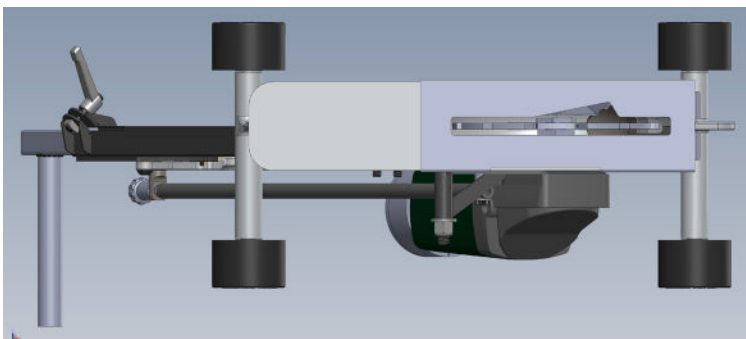

Figure 5 - MARK-III bottom view



CAUTION: The blade depth is approximate and not exact. Many variables affect the exact blade depth such as the exact diameter of a worn diamond blade. If an accurate depth must be cut, install the blade to be used with the motor in the OFF position. Place the MARK III in a secure position that allows the blade to overhang and be visibly measured at full blade depth. An example would be blocking the wheels with the motor in the OFF position and lowering the MARK III blade along side a street curb. This will allow a measurement from the bottom of the blade to the top of the curb.



WARNING: Breathable silica may be generated by use of this product. Silica can cause severe and permanent lung damage, cancer, and other serious diseases. Do not breath the dust. Do not rely on your sight or smell to determine if the dust is in the air. Silica may be in the air without a visible dust cloud. If air monitoring equipment for silica is not provided by your employer at your work site, you MUST wear appropriate respiratory protection when using or servicing the machine. Consult your employer and OSHA regarding the appropriate respiratory protection.



PRE-OPERATION CHECKLIST

5.7 Check for missing or loose bolts. Tighten loose bolts and replace missing bolts before operating machine. Verify that belt and blade guards are in place. Never operate a MARK-III without guards in place. See Figure 14 and Figure 15.



5.8 **WARNING:** If you can see the drive belt or diamond blade, the guards are not in place. Never operate a MARK III without guards in place. The proper position for the belt guard is bolted with four bolts to the chassis. The proper position for the blade guard is down with the white guard dust brush touching the horizontal surface. See Figure 14 and Figure 15.

5.9 Dress properly. Wear ear and eye protection. See sections 4.3 through 4.7. See Figure 16



5.10 **WARNING:** TO PREVENT SERIOUS INJURY DO NOT OPERATE SAW WITHOUT PROPER TRAINING.



Rotating blade hazard.
Do NOT operate with guard up.
Keep hands and feet away.

Figure 6 - Warning label - do not operate with guard removed



AVOID INJURY.
Do NOT operate with guard removed.
Replace guard before operating machine.

Figure 7 - Warning label - do not operate with guard up

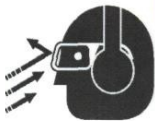

Flying debris and loud noise hazards. Wear ear and eye protection



Wear appropriate clothing

Figure 8 - Warning label - wear proper clothing, ear and eye protection



WARNING: Recommended accessories for this tool including blades are listed in this manual or are available by calling customer service. The use of any other attachment or accessory might be hazardous

5.11 MARK-III premium dry cut diamond blades, medium bond

CLEANING	DEPTH OF JOINT	SIZE	JOINT WIDTH (INCHES)			
			1/8 - 3/16	3/16 - 3/8	3/8 - 1/2	1/2 or more
Up to 2" Deep	8"	.095, .125, .187	.187, .250, .375	.375, .500	.095 + spacers	
		HARD	HARD	HARD	HARD	

REMOVAL	DEPTH OF JOINT	SIZE	JOINT WIDTH (INCHES)			
			1/8 - 3/16	3/16 - 3/8	3/8 - 1/2	1/2 or more
Up to 2" Deep	8"	.095 x 8 .125 x 8 .187 x 8	.187 x 8 .250 x 8 .375 x 8	.375 x 8 .500 x 8	.095 + .060 spacer x 8	
		MEDIUM	MEDIUM	MEDIUM	MEDIUM	

CUTTING	DEPTH OF JOINT	SIZE	JOINT WIDTH (INCHES)			
			1/8 - 3/16	3/16 - 3/8	3/8 - 1/2	1/2 or more
Up to 2" Deep	8"	.095 x 8 .125 x 8 .187 x 8	.187 x 8 .250 x 8 .375 x 8	.375 x 8 .500 x 8	.095 + .060 spacer x 8	
		SOFT	SOFT	SOFT	SOFT	

Table 9 - Dry cut diamond blade list
(* All blades are listed 5/8-7/8 arbor holes)



OPERATION

6.0 OPERATIONS

CLEANING OUT EXISTING JOINTS:

- 6.1 Follow all pre-operating instructions in section 5.0.
- 6.2 The machine should be unplugged from electricity before starting this operation.



WARNING: Never attempt to start the motor with the diamond blade inserted in a joint or previous cut. The blade will turn as soon as the MARK III is started. This could damage the blade or cause the MARK III to jump backwards.

- 6.3 Set the blade depth adjustment handle to the lowest point. (See Figure 9)

- 6.4 Remove the blade guard cover plate
- 6.5 Loosen, counterclockwise, the blade nut and remove it along with one of the two spacers. The inner arbor nut and one spacer will remain in place.



WARNING: If the blade you are using has a “5/8-7/8” knockout (brass bushing), remove it so that the arbor of the blade is set at 7/8”

- 6.6 Ensure the proper direction of the blade being used. This machine rotates the blade in an up-cut rotation which is counterclockwise.
- 6.7 Place the blade on top of the spacer that is already on the machine and line up the arbor hole.
- 6.8 Place the Outer blade spacer on top of the blade and line up the arbor hole.
- 6.9 Insert the shank of the Blade nut through the spacers and blade and thread onto the shaft of the grinder and tighten the nut with moderate force. Over tightening will cause problems when it's time to change the blade.
- 6.10 Raise the blade depth adjustment to it's highest point, replace the blade guard cover plate.



WARNING: Do not twist the blade in the cut. Never attempt to cut any pattern or follow any joint that is not a straight line. Do not force the blade forward. These actions could damage the blade and MARK III unit.

VACUUM HOSE ATTACHMENT:

- 6.11 The vacuum port is designed to be used with the 2” cuff that is standard on most industrial vacuums in the industry. The hose is meant to have a snug fit to prevent it from falling off during normal operation. *Cold weather will make the hose more difficult to slip over the vacuum port.

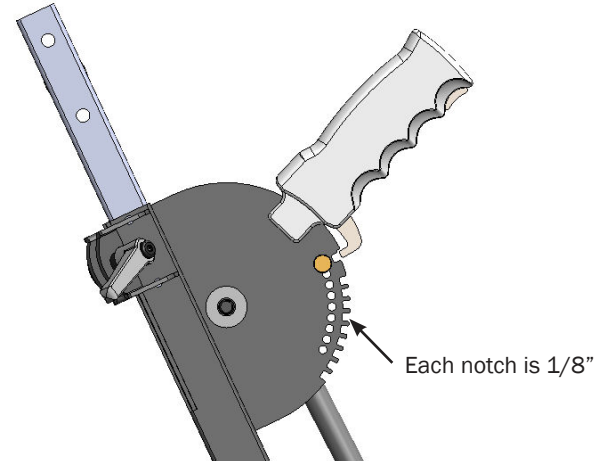

Figure 9 - MARK III SAWS blade depth setting



WARNING: Beware that after releasing the lever, the blade will continue spinning for several seconds. Keep a firm hold on the handle grips and maintain control of the machine until the blade completely stops.

- 6.12 This machine is intended to be used with a vacuum with 200cfm or more at all times. There is no instance where this machine should be used without a vacuum or with water.

SETTING THE BLADE DEPTH

- 6.13 Determine how deep you want the blade in the joint. An 8” blade will get a maximum of 2” depth and a 7” blade will get a maximum of 1.5” depth.
- 6.14 The accurate way: Lay the saw on its side in the same position you would to change the blade. Lower the blade until it is approximately where you want it. Measure with a tape measure or ruler to confirm the depth you want. Move the Brass “depth stop” thumb screw into the hole that coincides with the depth adjustment to prevent the blade from being lowered further than you want it. The “fine adjustment” knob on the left side of the blade depth adjustment assembly can be screwed in or out to make small adjustments to compensate for blade wear.
- 6.15 The quick way: With the saw “off”, lower the blade on a flat surface lifting the front wheels off the ground. The distance between the bottom of the wheel and the ground will be the approximate depth of cut +/- 1/8”.



WARNING: It is important to verify the depth of cut immediately after starting, and periodically during the job. If you are cutting deeper than you planned, you will use a lot more joint fill material than you had intended.



OPERATION

LINING UP THE BLADE WITH THE JOINT/POINTER ADJUSTMENT

6.16 Open Joint: With an un-filled control joint where it only needs to be cleaned of debris, it is better to line the pointer up with the left edge of the joint so that the pointer wheel rides along on the surface of the floor. If the pointer wheel is directly in the joint, it can get stuck and make it difficult to move the machine forward.

6.17 Filled Joint: The pointer wheel can be lined up directly in the center of the joint or off to the side edge. It is up to the operator to determine what they are more comfortable with.

6.18 Adjusting the pointer: Part # 49 in the parts breakdown is a "shaft collar clamp." To adjust the pointer, loosen the allen bolt, rotate the shaft collar clamp forward to move the pointer to the right, and rotate it backward to move the pointer to the left. Once the pointer wheel is in the desired position, re-tighten the allen bolt. One of the easiest ways to set the pointer is, with the saw off, put the blade down into a joint and move the saw back and forth a few feet while observing where the pointer wheel is in conjunction to the joint. This will show if the pointer is in a good location or if it needs adjustment.

OPERATING THE SAW:

6.19 Open Joint: Lower the blade to the desired depth into the open joint with the saw "off." Move the saw forward and backward to align the blade with the joint. Carefully, and without moving the position of the saw, raise the blade just above the surface. With the other hand, turn the saw on and lock the trigger. Slowly lower the blade into the joint. Once the blade is at its full depth, use two hands and guide the saw through the joint. The blade will follow the path of least resistance and therefore follow the joint with minimal effort. Tip: There may be some dust escaping through the front of the joint upon entry or if the joint is relatively clean to begin with. If this is the case and total dust control is necessary, it may be helpful to sweep some dry sand into the joint before running the saw through it. The sand will block the dust and direct it upward into the vacuum port and the blade will easily remove the sand.

6.20 Filled Joint: Line the blade up with the joint fill material to be removed, turn the saw on, and slowly lower the blade into the cut. The saw will be forced back toward the operator until the blade is at full depth. Do not force the saw forward. Let the rpm of the saw stay high and let the blade do the cutting. Forcing the blade will cause excessive heat and may make cutting slower. The saw must be guided in an accurate and skillful manner as to keep the saw in the joint fill material and not wander off into the concrete. This is especially important when removing polyurea.

6.21 Finishing a cut: When the operator gets to a wall or other termination point, with the blade still in the "down" position, shut the saw off and wait for the blade to stop. Retract the blade and move to the next cut and repeat the process. It is not recommended to tip the saw back on its rear wheels while the saw is still on and the blade is spinning. This is especially important on polished concrete floors to prevent accidental damage to the floor surface.

MKIII CAST DUST BUGGY HANDLE ASSEMBLY:

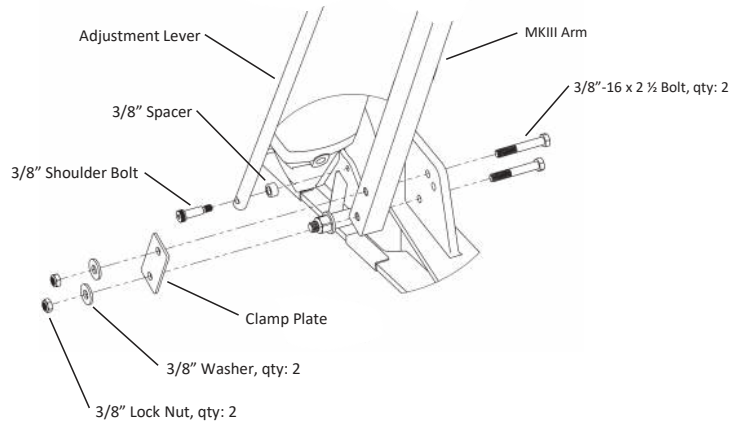

Figure 10 - MARK III SAWS Handle Assembly

- 6.22** Align bolt holes for Mark-III Arm in the most vertical position. And make sure the Adjustment Lever is in position.
- 6.23** Attach both 3/8"-16 bolts.
- 6.24** Attach Clamp Plate.
- 6.25** Attach 3/8" washers and tighten Lock nuts firmly.
- 6.26** Attach 3/8" Shoulder Bolt through Adjustment lever and spacer. Then tighten firmly to motor plate.

OTHER INFORMATION:

- 6.27** Use the shortest, heaviest gauge extension cord possible for your job. The longer the cord, the more power will be lost. The thinner the cord, the more heat will be generated and will eventually end up damaging the motor.
- 6.28** Keep the machine clean.
- 6.29** Don't get the machine wet
- 6.30** Clean dust out of the threads of the blade nuts before tightening.
- 6.31** Periodically check nuts and bolts for tightness
- 6.32** Familiarize yourself and your employees with the machine and its intended manner of use before using it.
- 6.33** Bring a variety of thickness of blade with you to every job.
- 6.34** Bring a good set of tools to every job.



PARTS BREAKDOWN

7.1 MARK-III SERIES SAWS Parts Breakdown

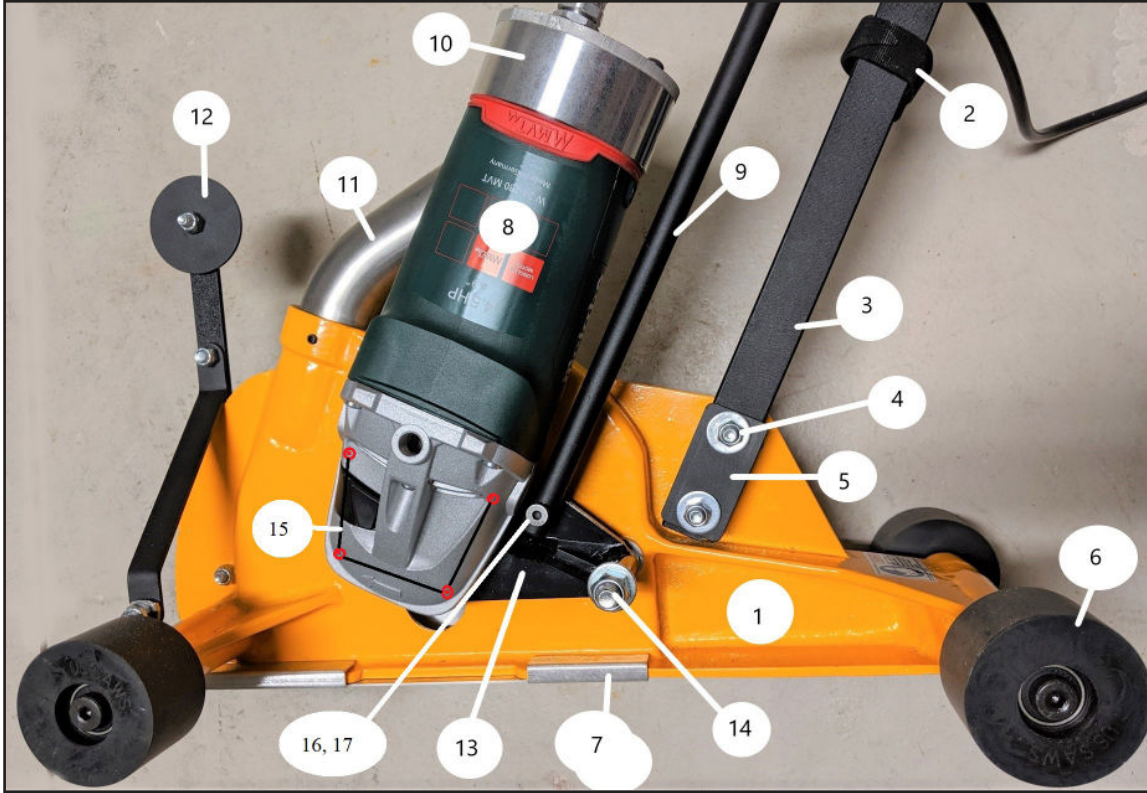

Reference Number	Part Number
1	SX13711
2	US32606
3	SX13730
4	US31158, Washer US31337, Nut US30152
5	SX113742
6	US31053-13
7	SX13753
8	SX13750
9	SX13740
10	See Expanded View
11	SX13751
12	See Expanded View
13	SX13720
14	US31222-9 Washer (2) US31351, Nut US31351-1
15	US31252-1 (4)
16	SX13741 (1)
17	US31624



PARTS BREAKDOWN



Reference Number	Part Number
15	SX13743
16	US31063-11, Washer US31127-10
17	US31102-1

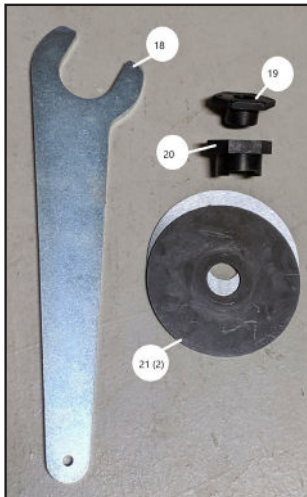

Reference Number	Part Number
18	US24154
19	SX65020
20	SX50501
21	PDC-SPA4

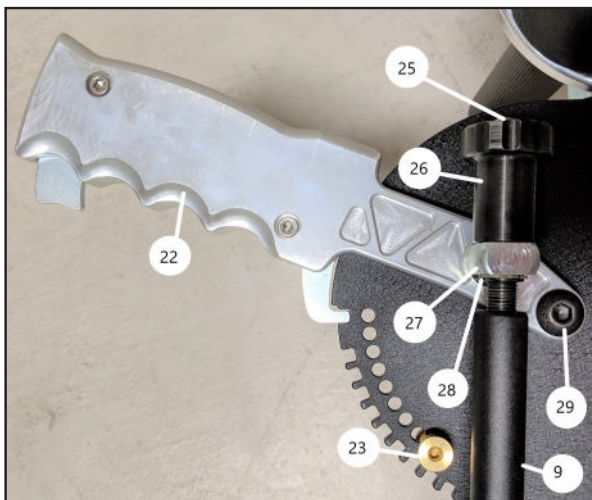

Reference Number	Part Number
9	SX13740
22	See Expanded View
23	US31063-11, Nut US31056-11
25	SX13739
26	SX13738
27	SX13737
28	US32102-5
29	US31168, Washer US31337, Nut US31052



PARTS BREAKDOWN



Reference Number	Part Number
30	SX13735
31	SX13734
32	SX13736
33	US31060-5
Spring	US31339-10



Reference Number	Part Number
34	US67112
35	US60223
36	US67111
37	US67114

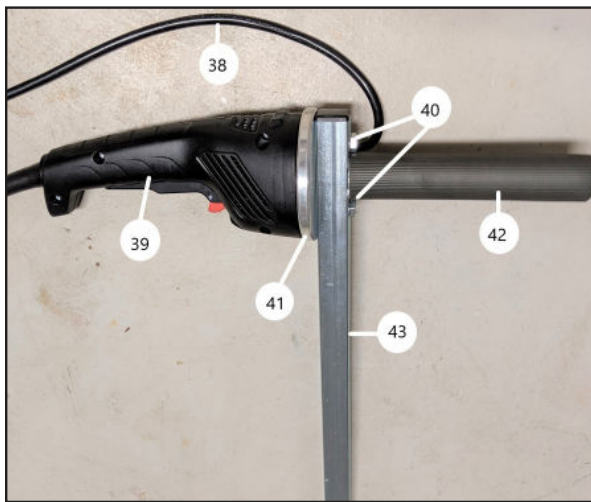

Reference Number	Part Number
38	US24600-33
39	*Comes as part of SXW24230
40	US31102-1
41	US67116
42	US32409
43	SX13733



PARTS BREAKDOWN



Reference Number	Part Number
30	SX13735
31	SX13734
32	SX13736
33	US31060-5
Spring	US31339-10



Reference Number	Part Number
34	US67112
35	US60223
36	US67111
37	US67114

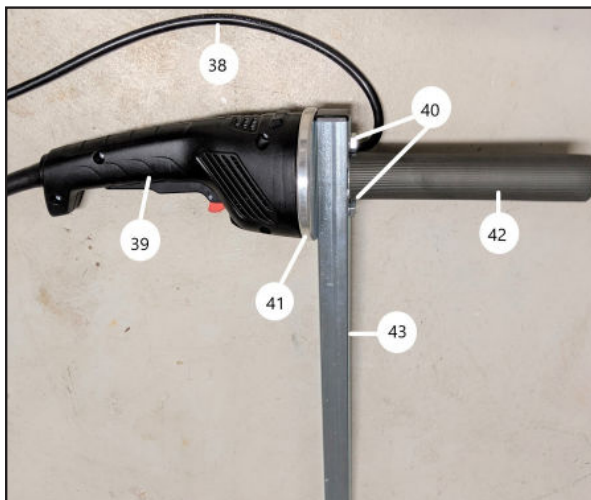

Reference Number	Part Number
38	US24600-33
39	*Comes as part of SXW24230
40	US31102-1
41	US67116
42	US32409
43	SX13733



PARTS BREAKDOWN

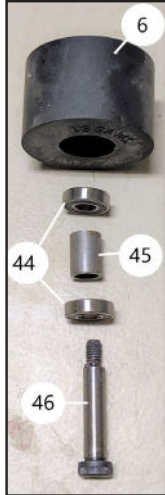

Reference Number	Part Number
6	US31053-13
44	US32235
45	US31053-14
46	US30176-1

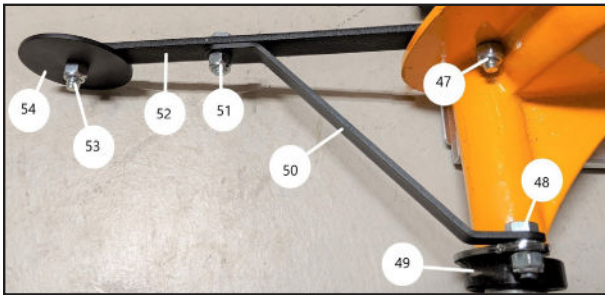

Reference Number	Part Number
47	US31102-1, Washer US31321, Nut US3110-1
48	US31102-1, Washer US31321, Nut US3110-1
49	US13572
50	US13572-1C
51	US31117-1, Nut US31110-1
52	SX13561-7
53	US31102-1, Washer US31321, Nut US3110-1
54	SX78119



RELATED PRODUCTS

General Joint Cleanout / Concrete Cutting

DCB08095UD 8 X .095 X 5/8-7/8 Supreme Grade Dry Cut Blade



DCB08125UD 8 X .125 X 5/8-7/8 Supreme Grade Dry Cut Blade



DCB08250UD 8 X .250 X 5/8-7/8 Supreme Grade Dry Cut Blade



Polyurea / Joint Filler Removal

APB08095D 8 X .095 X 5/8-7/8 TIGERTOOTH Diamond Grit Blade



APB08125D 8 X .125 X 5/8-7/8 TIGERTOOTH Diamond Grit Blade



WARRANTY AND SERVICE

8.0 WARRANTY AND SERVICE

8.1.1 Warranty

This document is to be used as a guide in determining warranty policies and procedures for U.S.SAWS and its U.S.SAWS products. It is to be used in determining whether a warranty is justified and as a procedural guide in completing a U.S.SAWS warranty claim form.

8.1.2 Warranty Responsibility

The distributor or the end user must prepare a Machine Warranty Information Card when the machine is delivered. Failure to comply will make any and all warranties on this equipment null and void. Credit for warranty repairs will be given only after receipt of the WARRANTY CLAIM FORM, properly completed with all the required details. Submittal details are described later in this document.

8.1.3 Warranty Policy

8.1.3.1 U.S.SAWS warrants its U.S.SAWS products against defects in material and workmanship under normal and proper use for a period of one year (365) days from the date of delivery; in the case of Rental Fleet Machines, date of assignment to Rental Fleet. Such warranty is extended only to the buyer who purchases the equipment directly from U.S.SAWS or its authorized distributor. This warranty does not include expendable parts such as, but not limited to, plugs, cutters, blades, blast wheel, wear parts, liners and seals.

8.1.3.2 The obligation under this warranty is strictly limited to the replacement or repair, at US SAWS's option, of machines and does not include the cost of transportation, loss of operating time, or normal maintenance services.

8.1.3.3 This warranty does not apply to failure occurring as a result of abuse, misuse, negligence, corrosion, erosion, normal wear and tear, alterations or modifications made to the machine without express written consent of U.S.SAWS .

8.1.3.4 Warranty request must be submitted in writing within thirty (30) days after failure.

8.1.3.5 Written authorization to return merchandise under warranty must first be obtained from U.S.SAWS .

8.1.3.6 U.S.SAWS reserves the right to inspect and make the final decision on any merchandise returned under warranty.

8.1.3.7 U.S.SAWS offers no warranty with respect to accessories, including but not limited to, engines, motors, batteries, electrical boards, tires and any other parts not manufactured by us but which the original manufacturer warrants.

8.1.3.8 U.S.SAWS reserves the right to make product changes or improvements without prior notice and without imposing any obligation upon itself to install the same on its products previously sold.

8.1.3.9 The above warranty conditions can only be altered by US SAWS. US SAWS must confirm alterations in writing for each specific transaction.

8.1.3.10 U.S.SAWS reserves the right to establish specific warranty terms for used or demo machines on an individual transaction basis. Invoices covering such merchandise will clearly state the provisions of the applicable warranty for each specific transaction.

8.1.3.11 WE DO NOT AUTHORIZE ANY PERSON, REPRESENTATIVE OR SERVICE OR SALES ORGANIZATION TO MAKE ANY OTHER WARRANTY OR TO ASSUME FOR US ANY LIABILITY IN CONNECTION WITH THE SALE OF OUR PRODUCTS OTHER THAN THOSE CONTAINED HEREIN.

8.1.3.12 UNDER NO CIRCUMSTANCES SHALL US SAWS BE LIABLE TO CUSTOMER OR ANY OTHER PERSON FOR ANY DIRECT, INCIDENTAL, OR CONSEQUENTIAL DAMAGES RESULTING FROM THE USE OF THE PRODUCT OR ARISING OUT OF ANY BREACH OF ANY WARRANTY OR FOR ANY SPECIAL OR CONSEQUENTIAL DAMAGES OF ANY CHARACTER, INCLUDING WITHOUT LIMITATIONS, DAMAGES FOR ANY LOSS OF GOODWILL, WORK STOPPAGE, OR ANY AND ALL OTHER COMMERCIAL DAMAGES OR LOSSES.

8.1.3.13 U.S.SAWS MAKES NO OTHER WARRANTIES, EXPRESSED OR IMPLIED, INCLUDING, BUT NOT LIMITED TO, THE IMPLIED WARRANTIES OF MERCHANTABILITY AND FITNESS FOR A PARTICULAR PURPOSE WITH RESPECT TO THE US SAWS PRODUCTS SOLD PURSUANT THERETO.



MACHINE WARRANTY INFORMATION CARD

TO ENSURE THE PROPER WARRANTY COVERAGE IS EXTENDED TO THE OWNER OF THIS MACHINE, FILL OUT THE ATTACHED CARD COMPLETELY AND ACCURATELY.

WARRANTY REGISTRATION CARD

IMPORTANT! To ensure that your U.S.SAWS machine is covered under warranty, please fill in the following information and mail or fax it to U.S.SAWS, 8004B E. Broadway Ave. Tampa, FL 33619, Fax No. (813) 621-7125

COMPANY
NAME
ADDRESS
INTENDED USE
DATE OF PURCHASE
INTENDED USE
SERIAL NUMBER

If you are not the owner of record as shown on the manual copy of the warranty registration card, do not operate this machine before contacting U.S.SAWS at 1-877-817-6687. Verify the following before operating the equipment:

CHANGE OF OWNER OR NEW ADDRESS REGISTRATION CARD

IMPORTANT! To ensure that your U.S.SAWS machine is covered under warranty, please fill in the following information and mail or fax it to U.S. SAWS, 8004B E. Broadway Ave. Tampa, FL 33619, Fax No. (813) 621-7125

COMPANY
NAME
ADDRESS
INTENDED USE
DATE OF PURCHASE
INTENDED USE
SERIAL NUMBER

18



**SURFACE PREP
DIVISION**

P: 877-817- 6687 F: 813-621-7125
Visit us at www.ussaws.com
sales@ussaws.com

