



HAWK
ENTERPRISES

HAWK Brute

Deluxe Severe Duty Floor Machine

Stripping, Sanding, Carpet Care, Resurfacing

Operation • Care • Service



HAWK ENTERPRISES

2902 Park Six Court, Elkhart, IN 46514

(574) 294-1910

(888) 289-4295

www.hawkenterprises.com

TABLE OF CONTENTS

Machine Specifications.....	1
Service Information	2
Important Safety Instructions.....	2
Grounding Instructions	3
Operations / Accessories	3
Brush And Drive Block Installation.....	4
Adjustments.....	4
Controls.....	5
Guidlines For Operation	5
Cord Storage	5
Clean Up And Storage	5
Floor Machine Assemblies.....	6
Floor Machine Parts List.....	7-8
Optional Accessories.....	9
Features	9
Limited Warranty	Back Cover

Machine Specifications

Specifications				
Model #	HP1513-180BRUTE	HP1515-180BRUTE	HP1517-180BRUTE	HP1520-180BRUTE
Part #	F0013-180CP	F0006-180CP	F0009-180CP	F0012-180CP
Machine Size	13 inch	15 inch	17 inch	20 inch
Pad Size	12 inch	14 inch	16 inch	19 inch
Pad Speed	165 RPM	165 RPM	165 RPM	165 RPM
Amp Draw	7.2 Amp	7.5 Amp	7.9 Amp	8.4 Amp
All Sizes				
Motor	1.5 HP, 180 frame, TEFC dual capacitor AC motor			
Power	115-230V, 60 Hz power			
Power Cord	50 ft., 12-3 SJTOW industrial power cord w/molded plug			
Drive System	Triple-planetary XHD 11:1 helical-cut industrial gears			
dB Rating	66 dB - Meets GS42 standard			

SERVICE INFORMATION

To obtain consistent performance over the life of your equipment, read through these instructions and save them for future reference. If you require service, contact the dealer from which the machine was purchased or an authorized service station. Always refer to your Limited Warranty for complete service information.

SERIAL NO.		MODEL
VOLTS	PHASE	HZ
MOTOR	AMPS	H.P.

The model, type, and serial number are indicated on the data plate on the side of the handle. For prompt and complete service, refer to these numbers when inquiring about service.

Write the model and serial number of your unit in the space provided. Refer to the data plate on unit.	
SERIAL #	MODEL #
Retain this owners manual for future reference.	

IMPORTANT SAFETY INSTRUCTION

When using an electrical appliance, basic precautions should always be followed, including the following:

READ ALL INSTRUCTIONS BEFORE USING THIS FLOOR MACHINE.



- Your floor machine is equipped with a safety switch lock and power switch triggers designed for your safety. Do not attempt to by pass or defeat the safety switch lock. Never use any device to lock the power switch triggers in the “ON” position.
- Do not leave the floor machine plugged in. Turn off the switch and unplug the electrical cord when not in use and before servicing or changing the brushes or pads.

- Do not allow the machine to be used as a toy. Close attention is necessary when used near children. Do not leave the machine connected to an electrical outlet unattended.
- Use only as described in this manual. Use only manufacturer’s recommended attachments.
- Do not use with a damaged cord or plug. If the machine is not working as it should, has been dropped, damaged, or left outdoors, return it to an aservice center before using.
- Use care to keep the electrical supply cord around sharp edges or corners. Keep the cord away from the heated surfaces.
- Connect to properly grounded (3-wire) outlet only. Refer to Grounding Instructions, Page 4.
- Do not use extension cords or outlets with inadequate current carrying capacity.
- Turn off all controls before unplugging.
- Do not unplug by pulling on the cord. To unplug, grasp the plug and pull.
- Do not handle the plug or floor machine with wet hands.
- Wind the cord no tighter than is necessary to retain it during storage. Refer to Cord Storage, Page 5.
- Use extra care when working on or near stairs.
- Do not use in conjunction with flammable or combustible liquids such as gasoline, or use in areas where explosive vapor or dust may be present.
- Store your floor machine indoors in a cool, dry area.
- Keep your work area well lit.
- **WARNING:** To avoid electrical shock, use indoors only.

GROUNDING INSTRUCTIONS

This appliance must be grounded. If it should malfunction or break down, grounding provides a path of least resistance for electric current to reduce the risk of electric shock. This appliance is equipped with a cord that has an equipment-grounding conductor and grounding plug. The plug must be plugged into an appropriate outlet that is properly installed and grounded in accordance with all local codes and ordinances.

FOR FLOOR FINISHING MACHINES RATED LESS THAN 150 VOLTS



WARNING: DO NOT USE GROUNDING ADAPTERS ON FLOOR MACHINES IN CANADA. CHECK WITH CANADIAN CODES FOR PROPER EQUIPMENT USAGE. IMPROPER USE OF GROUND ADAPTORS CAN CAUSE SERIOUS INJURY, FIRE, OR BE FATAL.

Improper connection of an equipment grounding conductor can result in risk of electric shock. Check with a qualified electrician or service person if you are in doubt as to whether the outlet is properly grounded. Do not modify the plug provided with the appliance. If it will not fit the outlet, have a proper outlet installed by a qualified electrician. This appliance is for use on a nominal 120 volt circuit and has a grounding plug that looks like the plug illustrated in Figure 1. A temporary adapter which looks like the adapter illustrated in Figure 2 may be used to connect this plug to a two pole receptacle, as shown, if a properly grounded outlet is not available. The temporary adapter should be used only until a properly grounded outlet (Figure 1) can be installed by a qualified electrician. The green colored rigid ear, lug, or the like extending from the adapter must be connected to a permanent ground such as a properly grounded outlet box cover. Whenever the adapter is used, it must be held in place by metal screw.

FOR FLOOR FINISHING MACHINES RATED 150-220 VOLTS:

If the machine is provided with an attachment plug cap as shown in Figure 3, it is intended for use on a 240 volt (nominal) circuit. No adapter is available for this cap.

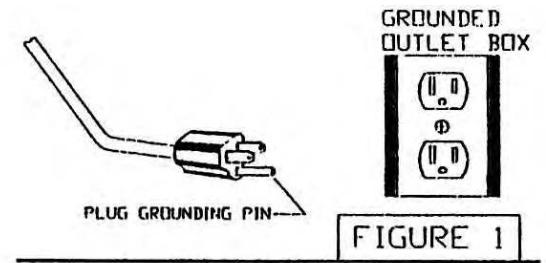

FIGURE 1

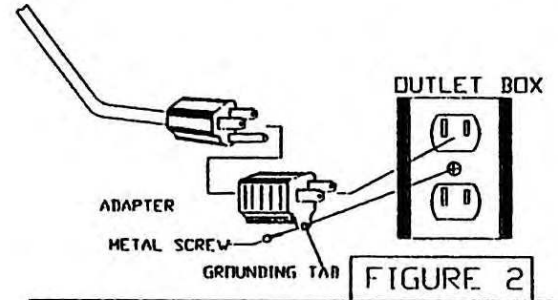

FIGURE 2

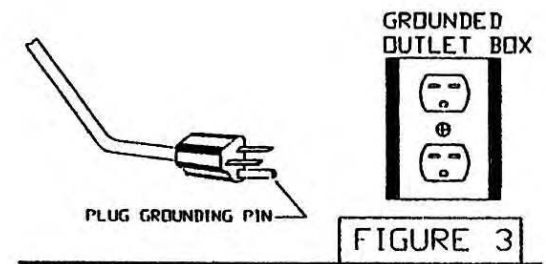

FIGURE 3

OPERATION / ACCESSORIES

CHOOSING THE RIGHT BRUSH AND DRIVE BLOCK

Your floor machine is packed completely assembled and ready for use after you install a brush or drive block.

Your floor machine is designed to be used for many different floor care applications. Make sure you use the correct brush or pad for the type of job you want to perform. (Accessories are available from the dealer from whom the floor machine was purchased. See Optional Accessories, Page 10)

When ordering brushes or drive blocks, refer to the following chart and specify correct brush or block diameter when ordering.

MACHINE SIZE	PAD DRIVER	BRUSH DIAMETER	BLOCK DIAMETER
13"	12"	13"	11"
15"	14"	15"	13"
17"	16"	17"	15"
20"	19"	20"	18"

Clutch plate A0019 is common on all models.

BRUSH AND PAD DRIVER INSTALLATION

NOTE: Disconnect the power cord from the electrical outlet before installing a brush or pad driver.

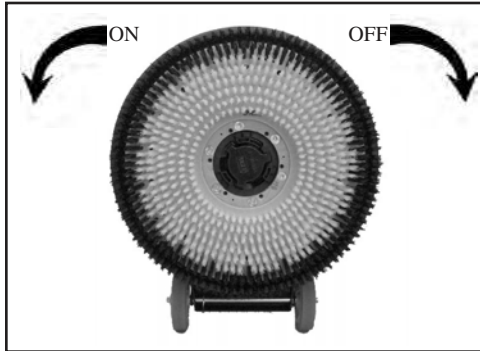

Figure 4

To install a brush or pad driver, leave the handle in the upright position and tip the machine backwards so it rests on its wheels and upper handle section (Figure 4). The brush and pad driver both attach in the same manner; align the cut-outs on the inner ring of the brush or pad driver with the tables on the inside of the ring of the drive hub (Figure 5). Push the brush or pad driver firmly in position, then turn it counter-clockwise until it locks into place. To remove, turn the brush or pad driver clockwise until it stops, and then lift it off. **NOTE:** Always remove the brush or pad driver when the machine is not in use.

NOTE: Disconnect power cord from the electrical outlet before installing or removing brush, pad, or pad driver.

ADJUSTMENTS HANDLE ADJUSTMENT

The handle can be adjusted to any desired work position by simply pushing up on the handle lock (Figure 5). Move the handle to the desired position, then firmly push down on the handle lock which will lock the handle in position.

HANDLE CAM LOCK ADJUSTMENT

With the handle cam lock in the “up” position (unlocked), tighten the adjusting nuts until there is a slight drag when the handle is raised or lowered. The tube should be locked securely when the handle lock is pressed downward (Figure 6).



Figure 5

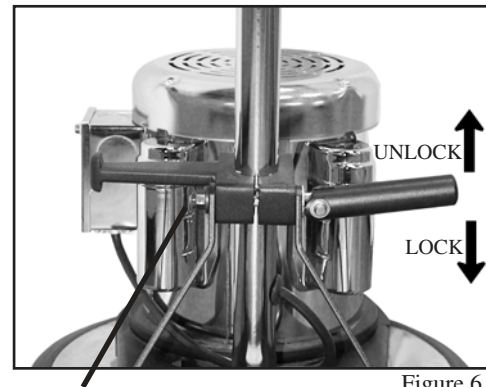

Figure 6

ADJUSTING NUT

CONTROLS ON/OFF POWER SWITCH TRIGGERS

The ON/OFF switch is conveniently located in the form of dual triggers underneath the handle grips.

TO TURN THE MACHINE ON

The operating handle must be lowered to the operating position before switching the machine ON. Place both hands firmly on the handle grips with your fingers around the power triggers. Do NOT apply pressure on the triggers before the safety switch lock is disengaged.

Disengage the safety switch lock by pushing it forward with one thumb. Then, while holding the safety switch lock in the disengaged position, squeeze the power triggers toward the handle grips and return your thumb to the handle grip. (See figure 7)

To stop the machine, simply release the triggers. The safety switch lock will automatically return to the engaged position. (See figure 7)

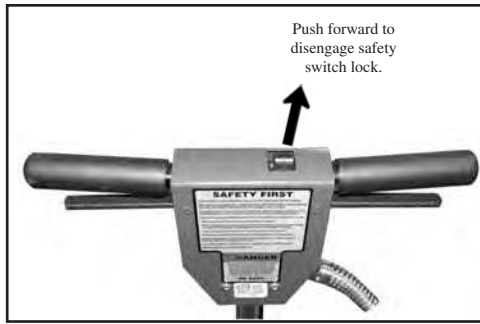

Figure 7

GUIDELINES FOR OPERATON

- Your floor machine is a very sensitive, powerful unit. When in operation, it should be guided gradually and smoothly without sudden or rough motions. You will want to practice with your machine on a smooth surface until you have experience in operating it.
- For ease of operation, always keep the brush or pad surface level, balanced, and flat on the floor at all times.
- Always adjust the operating handle to a comfortable height at which the brush or pad surface is balanced before starting the machine. (See Handle Adjustment Page 4)
- Your floor machine will operate differently on various surfaces. For example, there will be much more resistance when the machine is used with a brush on carpeted surfaces than when it is used with a pad on a smooth surface. The operator should be prepared to adjust for these differences.
- **BEGIN OPERATING THE FLOOR MACHINE WITH THE BRUSH OR PAD SURFACE LEVEL, BALANCED AND FLAT ON THE FLOOR.**
- To move the machine to the right, slowly apply slight upward pressure on the handle.
- To move the machine to the left, slowly apply slight downward pressure on the handle.
- To move the machine forward or backward, keep the brush or pad flat on the floor and push or pull the machine in the desired direction.

DO NOT LET THE MACHINE REST ON THE PAD OR BRUSH FOR AN EXTENDED PERIOD OF TIME. This may alter the shape of the pad or brush which may cause the machine to wobble.

CORD STORAGE

When not in use, loosely wind the power cord around the cord storage hook on the handle shaft and both of the handle grips, as shown:

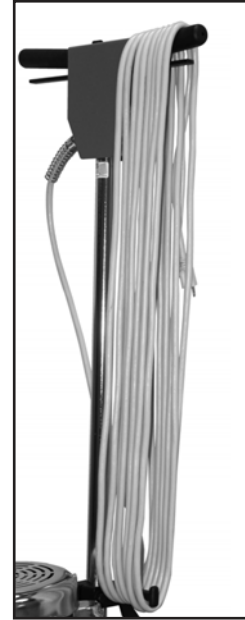

CLEAN UP AND STORAGE

After being used, your floor machine can be wiped clean with a soft, damp cloth and should be stored in a clean, dry place.

HAWK

BRUTE

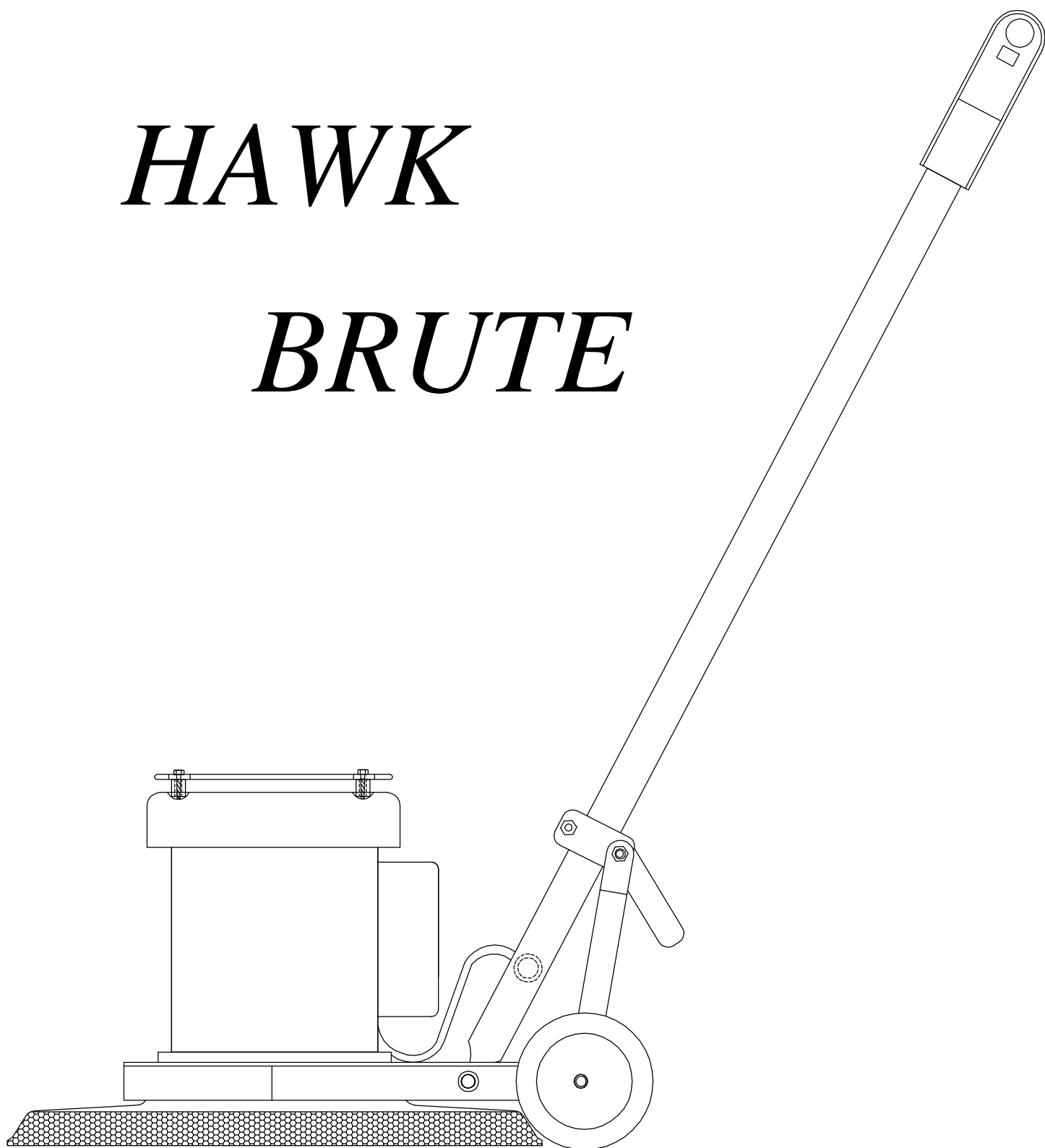

SERVICEABLE MOTOR PARTS

1.5 HP. LEESON MOTOR	
DESCRIPTION	HAWK P/N
START CAPACITOR	CAP-START
RUN CAPACITOR	CAP-RUN
STATIONARY SWITCH	
CENTRIFUGAL SWITCH	
TOP-MOTOR DRIP-COVER	

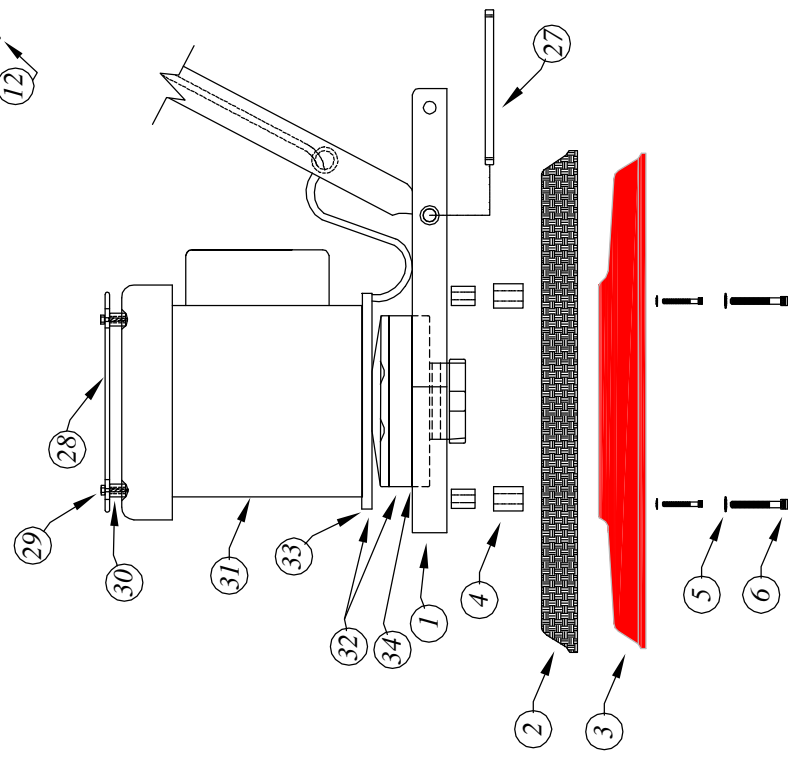
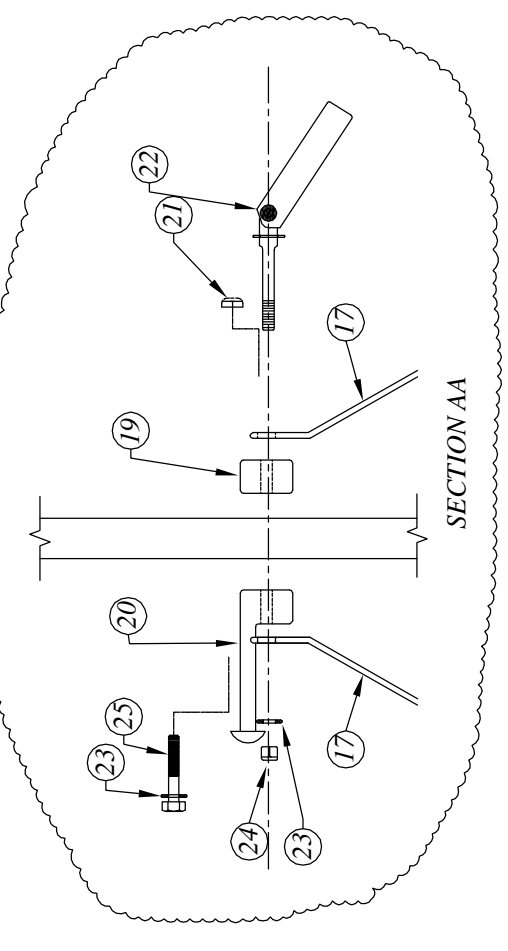
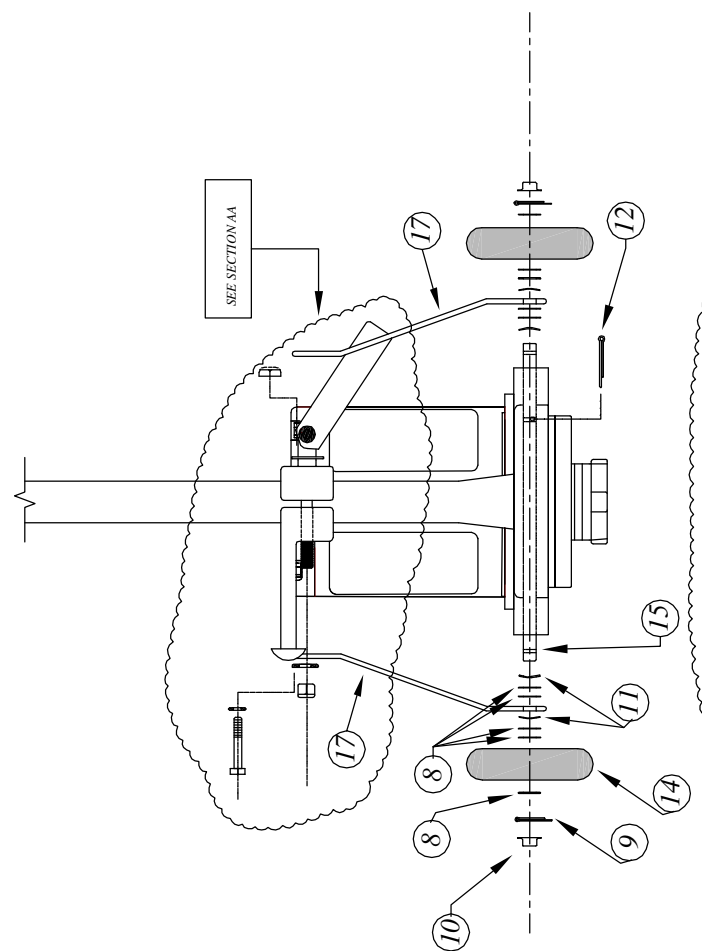
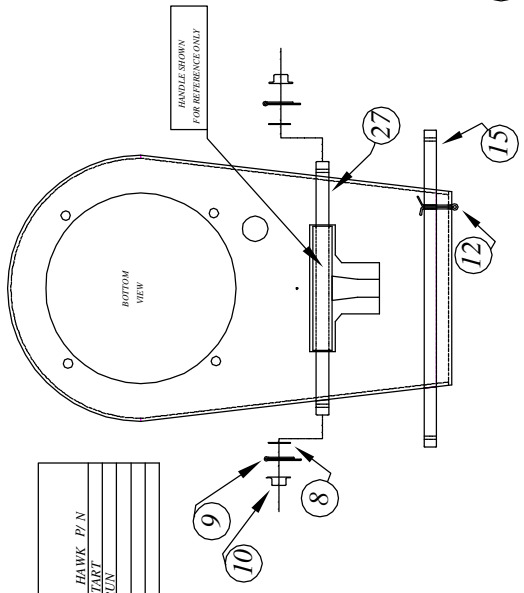

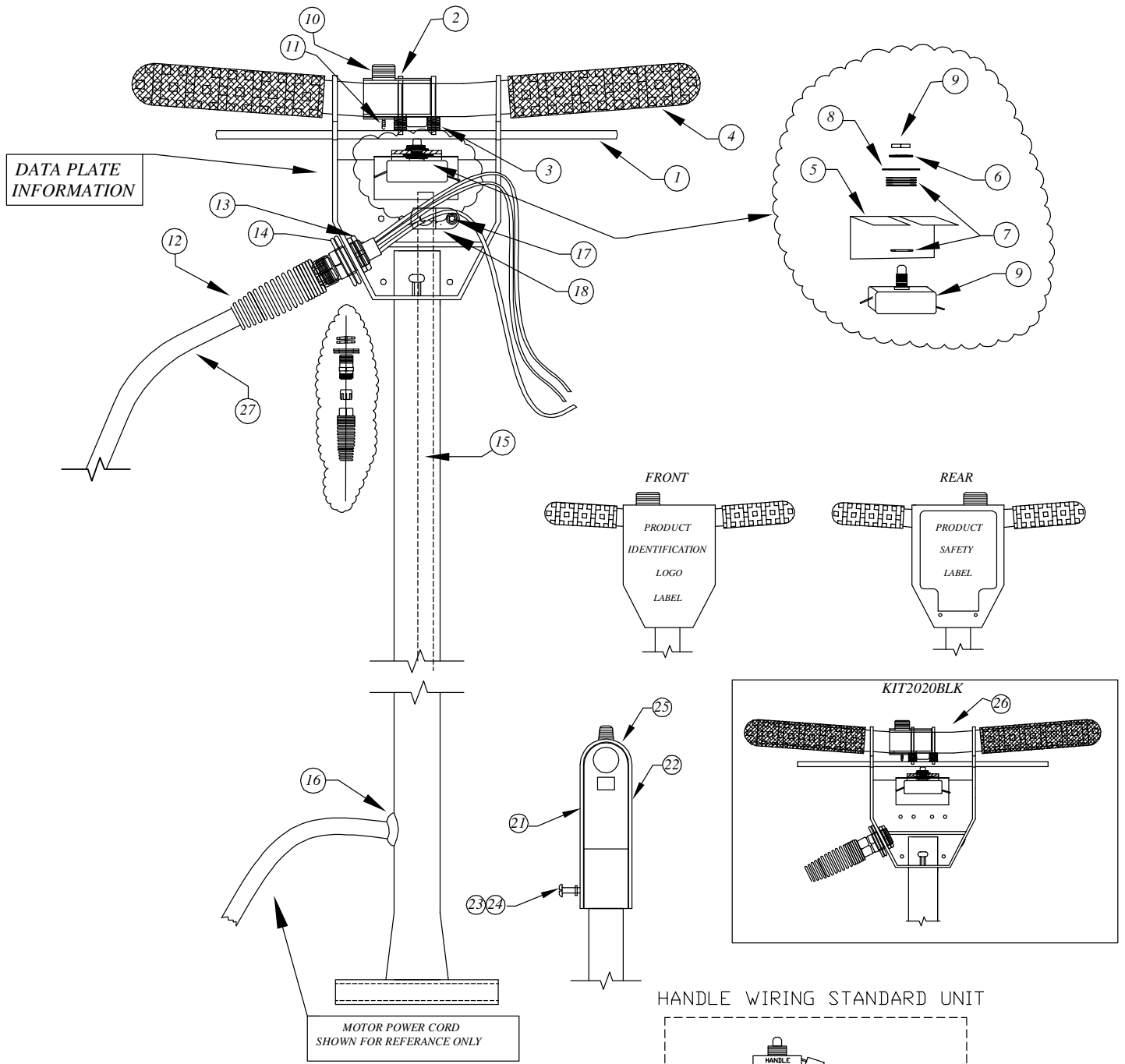

DATA PLATE INFORMATION

FRONT

REAR

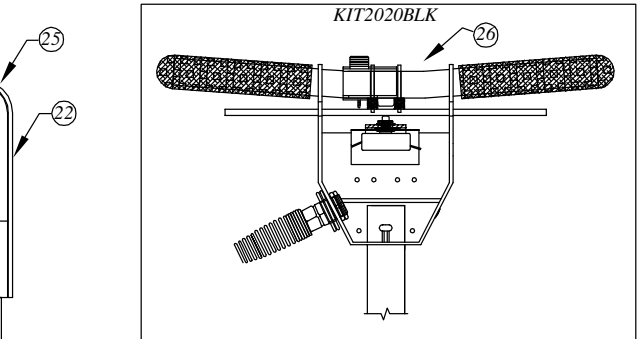

HANDLE WIRING STANDARD UNIT

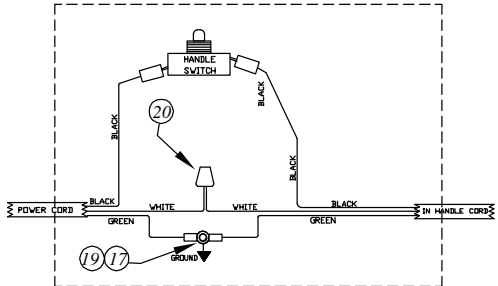

1/25/2016

PART		HANDLE ASSY STD FLOOR MACHINE	
DET. NO:	NUMBER	DESCRIPTION	QTY.
KIT3011BLK		TRIGGER REPLACEMENT KIT 14 INCH BLK	1
1	INC IN KIT3011BLK	TRIGGER 14 INCH - BLACK	1
2	INC IN KIT3011BLK	ROLL PIN	2
3	INC IN KIT3011BLK	SPRING - TRIGGER	2
KIT2011BLK		HANDLE GRIP REPLACEMENT KIT	1
4	INC IN KIT2011BLK	HANDLE GRIP - BLK	2
KIT1005		SWITCH - MAIN REPLACENENT KIT	1
5	INC IN KIT1005	SWITCH INSULATION	1
6	INC IN KIT1005	WASHER LOCK INT. TOOTH 3/8 ZN	1
7	INC IN KIT1005	WASHER FLAT STEEL ZN	5
8	INC IN KIT1005	WASHER FLAT 5/16 ZN	1
9	INC IN KIT1005	SWITCH - MAIN	1
KIT2006		SAFETY SWITCH REPLACEMENT KIT	1
10	INC IN KIT2006	SAFETY SWITCH	1
11	INC IN KIT2006	SPRING - SAFETY SWITCH	1
KIT2005		STRAIN RELIEF REPLACEMENT KIT	1
12	INC IN KIT2005	STRAIN RELIEF	1
13	INC IN KIT2005	NUT CONDUIT STRAIN RELIEF	1
14	INC IN KIT2005	WASHER STRAIN RELIEF-ZN	1
KIT1002		HANDLE (STD) HDWR & IN HANDLE CORD REPLACEMENT KIT	1
15	INC IN KIT1002	IN HANDLE REPLACEMENT CORD (STD) UNITS	1
16	INC IN KIT1002	GROMMET IN HANDLE CORD	1
17	INC IN KIT1002	SCREW 10-24 X .50 THRD ROLL PHIL PAN ZN	4
18	INC IN KIT1002	IN HANDLE LOOP CLAMP	1
19	INC IN KIT1002	WASHER #10 EXT. TOOTH LCK	5
20	INC IN KIT1002	WIRE NUT	3
KIT3008RED		SWITCH BOX REPLACEMENT KIT	1
21	INC IN KIT1008RED	LABEL - REAR SAFETY WARNING	1
22	INC IN KIT1008RED	LABEL - FRONT	1
23	INC IN KIT1008RED	SCREW 10-24 X .50 THRD ROLL PHIL PAN ZN	2
24	INC IN KIT1008RED	WASHER #10 EXT. TOOTH LCK	2
25	INC IN KIT1008RED	SWITCH BOX COVER - RED	1
KIT2020BLK		HANDLE WDNT STD. WITH THE FOLLOWING KITS INSTALLED	1
26		HANDLE WDNT STD. WITH THE FOLLOWING KITS INSTALLED	
	INC IN KIT2020BLK	HANDLE WDNT CHROME PLATED	1
	INC IN KIT2020BLK	KIT3011BLK TRIGGER REPLACEMENT KIT 14 INCH BLK	1
	INC IN KIT2020BLK	KIT2011BLK HANDLE GRIP REPLACEMENT KIT	1
	INC IN KIT2020BLK	KIT1005 SWITCH - MAIN REPLACENENT KIT	1
	INC IN KIT2020BLK	KIT2006 SAFETY SWITCH REPLACEMENT KIT	1
	INC IN KIT2020BLK	GROMMET IN HANDLE CORD	1
	INC IN KIT2020BLK	KIT2005 STRAIN RELIEF REPLACEMENT KIT	1
KIT1032		POWER CORD & STRAIN RELIEF REPLACEMENT KIT	1
27	INC IN KIT1032	E0003Y-1 POWER CORD	1
	INC IN KIT1032	KIT 2005 STRAIN RELIEF KIT	1

1/24/2015

DETAIL NUMBER	PART NUMBER	BRUTE / TEXHD MACHINE DESCRIPTION	QTY. REQ'D
KIT3012BLK		FRAME STD. MACHINE	1
1	INC IN KIT3012BLK	FRAME STD. - 2 SPEED BLK	1
		SEE DATA PLATE FOR PROPER BRUSH COVER SIZE	
KIT3013RED		BRUSH COVER 13 INCH W/BLK BUMPER	1
2	INC IN KIT3013RED	BUMPER 13 INCH BLK	1
3	INC IN KIT3013RED	BUSH COVER 13 INCH - RED	1
KIT3015RED		BRUSH COVER 15 INCH W/BLK BUMPER	1
2	INC IN KIT3015RED	BUMPER 15 INCH BLK	1
3	INC IN KIT3015RED	BUSH COVER 15 INCH - RED	1
KIT3017RED		BRUSH COVER 17 INCH W/BLK BUMPER	1
2	INC IN KIT3017RED	BUMPER 17 INCH BLK	1
3	INC IN KIT3017RED	BUSH COVER 17 INCH - RED	1
KIT3020RED		BRUSH COVER 20 INCH W/BLK BUMPER	1
2	INC IN KIT3020RED	BUMPER 20 INCH BLK	1
3	INC IN KIT3020RED	BUSH COVER 20 INCH - RED	1
KIT2015		BRUSH COVER HARDWARE MTG. KIT	1
4	INC IN KIT2015	SPACER 1.5 L	4
5	INC IN KIT2015	WASHER LOCK 5/16	4
6	INC IN KIT2015	SCREW SOCKET CAP 5/16-18 X 2.0L	4
KIT2010		HARDWARE KIT STD. MACHINE	1
8	INC IN KIT2010	FLAT WASHER ZINC	10
9	INC IN KIT2010	COTTER PIN 3/32 X 1.0L ZN	4
10	INC IN KIT2010	PUSH NUT .500 PLATED	4
11	INC IN KIT2010	WASHER SPRING .505 ID ZN	4
12	INC IN KIT2010	COTTER PIN 5/32 X 1.25L ZN	1
KIT2007		WHEEL KIT STD. MACHINE COMPLETE W/HDWR	1
14	INC IN KIT2007	WHEEL 5.0 INCH W/BALL BEARING	2
15	INC IN KIT2007	AXLE WHEEL PLATED	1
	INC IN KIT2007	KIT2010 HARDWARE KIT STD. MACHINE	1
KIT3006BLK		STANDARD MACHINE CONNECTING LEG KIT BLACK	1
17	INC IN KIT3006BLK	CONNECTING LEG BLACK	2
	INC IN KIT3006BLK	KIT 2010 HARDWARE KIT STD. MACHINE	1
KIT3010BLK		HANDLE CLAMP, CORD HOOK & CAM LOCK ASSY KIT COMP	1
19	INC IN KIT3010BLK	CORD HOOK CAP-BLK	1
20	INC IN KIT3010BLK	CORD HOOK -BLK	1
21	INC IN KIT3010BLK	NUT NYLOC THN .375-16 ZN	1
22	INC IN KIT3010BLK	CAM LOCK ASSY - BLK	1
23	INC IN KIT3010BLK	WASHER FLAT .375 BLK OXIDE	2
24	INC IN KIT3010BLK	NUT NYLOC FULL .375-16	1
25	INC IN KIT3010BLK	BOLT .375-16 X 2.0L GR8 BLK	1
KIT2018		HANDLE SHAFT STANDARD MACHINE KIT	1
27	INC IN KIT2018	HANDLE SHAFT STANDARD MACHINE PLATED	1
	INC IN KIT2018	KIT2010 HARDWARE KIT STD. MACHINE	1
KIT2022		MOTOR FAN GUARD KIT 180F TEFC	1
28	INC IN KIT2022	GUARD	1
29	INC IN KIT2022	SCREW 2.5L X #12 SCK HD SHT MTL	4
30	INC IN KIT2022	SPACER	4
		SEE DATA PLATE FOR PROPER MOTOR INFORMATION	
KIT1022CHROME		MOTOR 180F CHROME TEFC W/ GEARBOX INSTALLED	1
31	INC IN KIT1022CHROME	MOTOR CHROME 180F TEFC	1
32	INC IN KIT1022CHROME	GEARBOX XHD 3 IDLER W/FLANGE	1
33	KIT1025	GEARBOX XHD 3 IDLER (FLANGE ONLY)	1
34	KIT1018	GEARBOX XHD 3 IDLER ONLY (NO FLANGE)	1
KIT1022BLK		MOTOR 180F PAINTED TEFC W/ GEARBOX INSTALLED	1
31	INC IN KIT1022BLK	MOTOR TEXHD 180F TEFC	1
32	INC IN KIT1022BLK	KIT1030 GEARBOX XHD 3 IDLER W/FLANGE	1
33	KIT1025	GEARBOX XHD 3 IDLER (FLANGE ONLY)	1
34	KIT1018	GEARBOX XHD 3 IDLER ONLY (NO FLANGE)	1

LIMITED WARRANTY

Your HAWK equipment which has been manufactured, tested and inspected in accordance with carefully specified engineering requirements, is warranted to be free from defects in material and workmanship. This Limited Warranty is, however, subject to the Following qualifications, conditions and limitations which are set forth to provide you and all users of the HAWK equipment with information concerning the duration, extent, availability, and applicability of this HAWK Limited Warranty, the procedure to be taken to obtain its performance, and other information concerning the **HAWK Limited Warranty policy**.

The HAWK ENTERPRISES Limited Warranty is extended to the original end user as follows:

Machines: 3 year parts replacement and 1 year service labor warranty.

Replacement parts guaranteed for 90 days from date of installation against defects in material and workmanship.

This Limited Warranty will not cover damage attributable to the following:

- (1) Improper, unreasonable or negligent use or abuse of the equipment
- (2) Abrasions or punctures of the equipment.

The start date of the Limited Warranty coverage shall be the purchase date of the original end user or six months from the date the machine was shipped from the Factory, whichever comes first.

PARTS OF EQUIPMENT NOT COVERED BY THE LIMITED WARRANTY

Certain parts of equipment require replacement in the ordinary use due to normal wear by reason of their characteristics. Normal wear items such as cords, switches, bumpers, bearings, etc. are excluded from the Limited Warranty.

EXCEPTIONS AND EXCLUSIONS FROM THE LIMITED WARRANTY

This equipment is required to be used on electric current as indicated on the data plate. Otherwise damage, defects, malfunctions or other failure of the equipment arising from use on electric current not as indicated are excepted and excluded from this Limited Warranty. Defects, malfunctions, failure or damage of the equipment caused by improper, unreasonable or neglect use or abuse while in possession of the purchaser are likewise excluded from this warranty. If repair is done on your equipment by anyone other than those designated as authorized to perform such work without first having obtained factory instructions, HAWK ENTERPRISES at its sole option, may determine that this warranty will not apply and that reimbursement for such repair will not be made because of the failure to comply with such factory specified instructions.

PROCEDURE TO BE TAKEN TO OBTAIN PERFORMANCE OF LIMITED WARRANTY REPAIR

To secure repair of the equipment or any warranted parts under this Limited Warranty, the following procedure should be taken. The inoperative equipment or warranted parts, together with satisfactory evidence of the purchase date, must be delivered, with shipping and delivery charges prepaid, to one of the following:

- (1) The dealer from whom purchased;
- (2) Any HAWK distributor's service department in the United States;
- (3) Any HAWK authorized service station in the United States.

If you are unable to locate any of the foregoing, you may write or otherwise communicate with HAWK ENTERPRISES before repair service is performed by anyone else. In such event, HAWK ENTERPRISES will provide either the location or a closely available HAWK distributor service department, or HAWK authorized service station or other factory instructions. Upon compliance with the above procedure, all warranted defects will be repaired, at no additional charge or costs to the customer, and the repaired product returned to the customer, with all shipping and delivery charges pre-paid. In following the procedures set forth, PLEASE MAKE CERTAIN to state the model, type and serial number as shown on the data plate of the equipment.

REPLACEMENT

In the event of a defect, malfunction or failure of your HAWK equipment or any warranted part to conform with this warranty, HAWK may, at its sole option and own expense, replace the equipment or any warranted part with another new, identical or reasonably equivalent model or part in lieu or repairing the defect.

NO REFUND OF PURCHASE PRICE

HAWK will not, as a matter of its Limited Warranty policy, refund the customer's purchase price.

LIMITED WARRANTY REGISTRATION CARD FOR YOUR EQUIPMENT AND REQUEST FOR INFORMATION

Your HAWK distributor from whom you purchased your equipment is responsible for the registration of your Limited Warranty with the factory. Any information or questions you may have concerning your HAWK ENTERPRISES equipment or this Limited Warranty may likewise be secured from the factory. This Limited Warranty will give you specific legal rights, and you may also have other rights which vary from state to state.